



Flaming River Ind.
800 Poertner Dr
Berea, OH 44017
800-648-8022

*62-67 Nova Front Steer
Rack and Pinion
Conversion Kit*



Nova



For safety, disconnect battery cables and ensure that vehicle is properly supported by jack stands.

NOTE: Hoses (FR1610) and Pump Mounting Brackets (FR1612–Small Block or FR1613–Big Block) sold separately and not included in this kit.

68-69 Camaro Outer Tie Rod Ends Part # ES381RL must be used with this rack and pinion kit. (Must purchase separately from local or online auto parts supplier)

Before paint or powder coating of the rack and pinion cradle system we recommend that you prefit the system to ensure proper fit.

NOTE: A front end alignment is necessary after installation.

NOTE: The use of Flaming River Small Block Headers may be necessary with use of the Power Rack and Pinion System. Part No. FR50004C

NOTE: Flaming River Recommends that you use synthetic or high grade power steering fluid.

Kit Inventory	pg 3-4
Original System Removal.....	pg 5-6
Rack and Cradle Installation	pg 7
Tilt Column Installation.....	pg 8
Universal Joint and Steering Shaft Installation	pg 9
Steering Wheel Installation	pg 10
Power Steering Pump Installation.....	pg 11-12
Power Steering Bleeding Procedure	pg 13

WARRANTY DISCLAIMER: Flaming River's® Limited Warranty

Flaming River® warrants its products to be free from defects in material and workmanship for a period of one (1) year after the date of purchase, except that: All steering columns are warranted for a period of three (3) years from the date of purchase. The Big Switch (part number FR1005) is warranted for a period of three (3) years from the date of purchase, provided that it is not mounted with a steel bracket and provided further that it is adequately protected from environmental conditions. All electrical products other than the Big Switch are warranted for a period of ninety (90) days from the date of purchase. Flaming River's® warranty liability is limited to the replacement of defective products. Flaming River® is not liable for any labor costs associated with any warranty claim, or for any incidental or consequential damages. Improper installation, abuse, racing, and/or modification of the products voids this warranty. No warranty of merchantability or fitness for a particular purpose is made by Flaming River® with respect to any of its products. Warnings and Recommendations It is the customer's responsibility to determine the suitability of a given Flaming River® product for the customer's uses. Likewise, it is the customer's responsibility to install a Flaming River® product. Contact the vehicle manufacturer whenever installing a switch to confirm the appropriateness of using such a switch and the recommended placement of the switch on the vehicle. Use qualified chassis specialists for the installation of all steering related components. Be aware that the installation of certain Flaming River® products may adversely impact a manufacturer's warranty with respect to certain vehicles and other manufactured goods. Flaming River will repair or replace any product found to be defective in material or workmanship. Improper installation, abuse, racing and/or modification VOID WARRANTY. Flaming River® is not responsible for any labor costs associated with any warranty.

Item No.	Part No.	Description	Qty
1	WASH-5/16"	5/16" Flat Washer Grade 8 Equ	8
2	NUT-5/16-18	Nylock Lock Nut 5/16-18	8
3	BOLT-5/16-18X1.25	5/16-18 Bolt x 1 1/4" Long	8
4	FRPMP5B-V	Power Steering Pump w/ V-Belt Pulley	1
5	FRDMDCL	FR Domed Decal	1
6	100470	Nova Rack/Cradle Assembly Power	1
7	FR20118-1	Hazard Kit	1
8	FR20114-3	OEM Half Mount	1
9	FR20005	30" Paintable Tilt Column, 2" O.D.	1
10	FR1969	FR Power x 3/4" DD Universal Joint	1
11	FR1934	1" DD x 3/4" DD Universal Joint	1
12	FR1920	3/4" DD x 3/4" DD Universal Joint	1
13	FR1850	18" Length of 3/4" DD Shaft	1
14	FR1810	Zinc 3/4" Support Bearing	1
15	FR1614	Power Steering Fluid Reservoir	1
16	BK10200	Support Bearing Bracket, Bent	1
17	101943	Nova Column Mounting Clamp	1
18	100594	Chevy II Spindle Arm/Sleeve Kit	1

*1962-67 Nova
Front Steer
Cradle and Shaft
Assembly-Power*

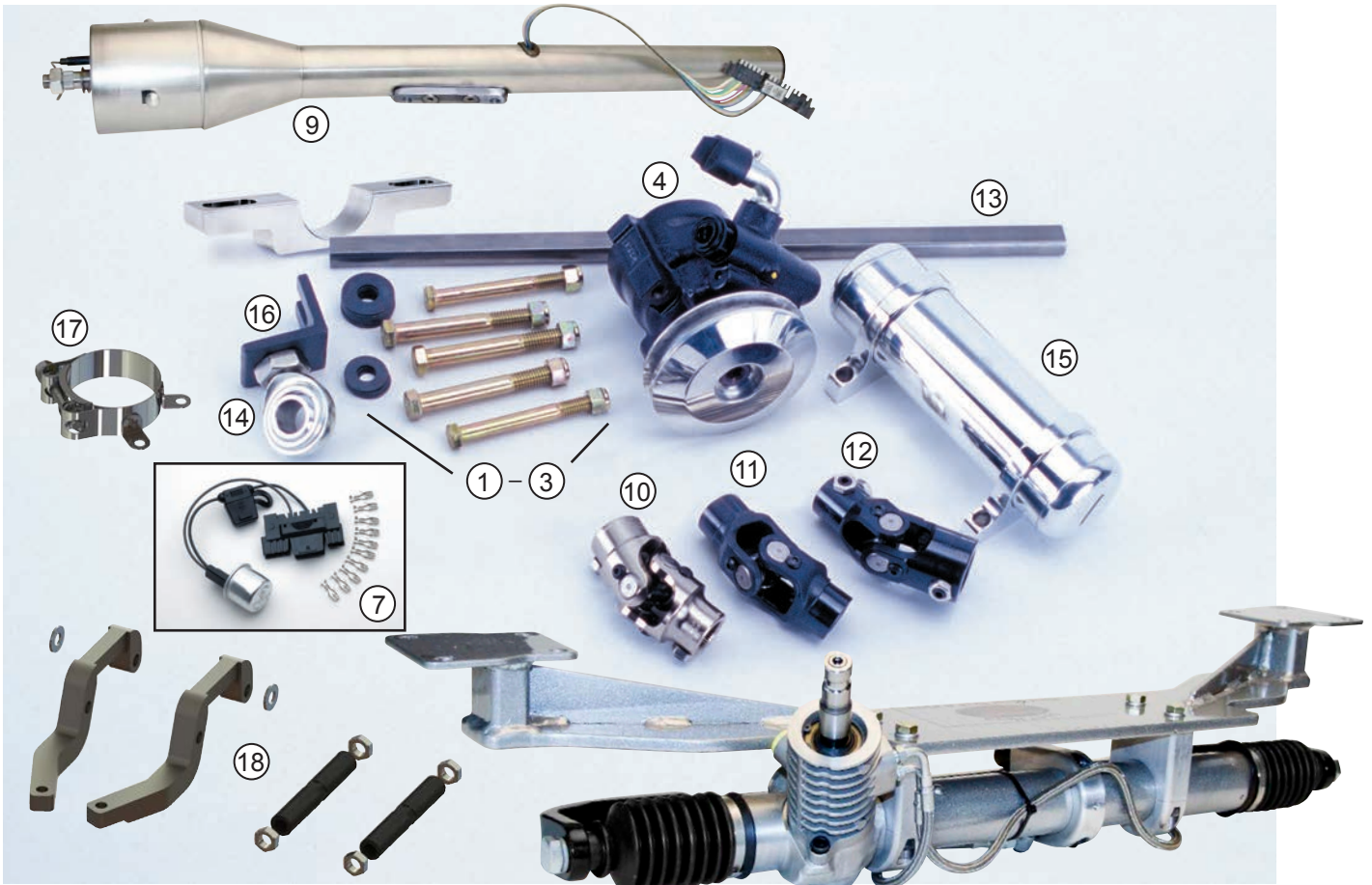

Item No.	Part No.	Description	Qty
1	WASH-5/16"	5/16" Flat Washer Grade 8 Equ	8
2	NUT-5/16-18	Nylock Lock Nut 5/16-18	8
3	BOLT-5/16-18X1.25	5/16-18 Bolt x 1 1/4" Long	8
4	FRDMDCL	FR Domed Decal	1
5	100683	Nova Rack/Cradle Assembly Manual	1
6	FR20118-1	Hazard Kit	1
7	FR20114-3	OEM Half Mount	1
8	FR20005	30" Paintable Tilt Column, 2" O.D.	1
9	FR1709DD	9/16-26 x 3/4" DD Universal Joint	1
10	FR1934	1" DD x 3/4" DD Universal Joint	1
11	FR1920	3/4" DD x 3/4" DD Universal Joint	1
12	FR1850	18" Length of 3/4" DD Shaft	1
13	FR1810	Zinc 3/4" Support Bearing	1
14	BK10200	Support Bearing Bracket, Bent	1
15	101943	Nova Column Mounting Clamp	1
16	100594	Chevy II Spindle Arm/Sleeve Kit	1

*1962-67 Nova
Front Steer
Cradle and Shaft
Assembly Manual*

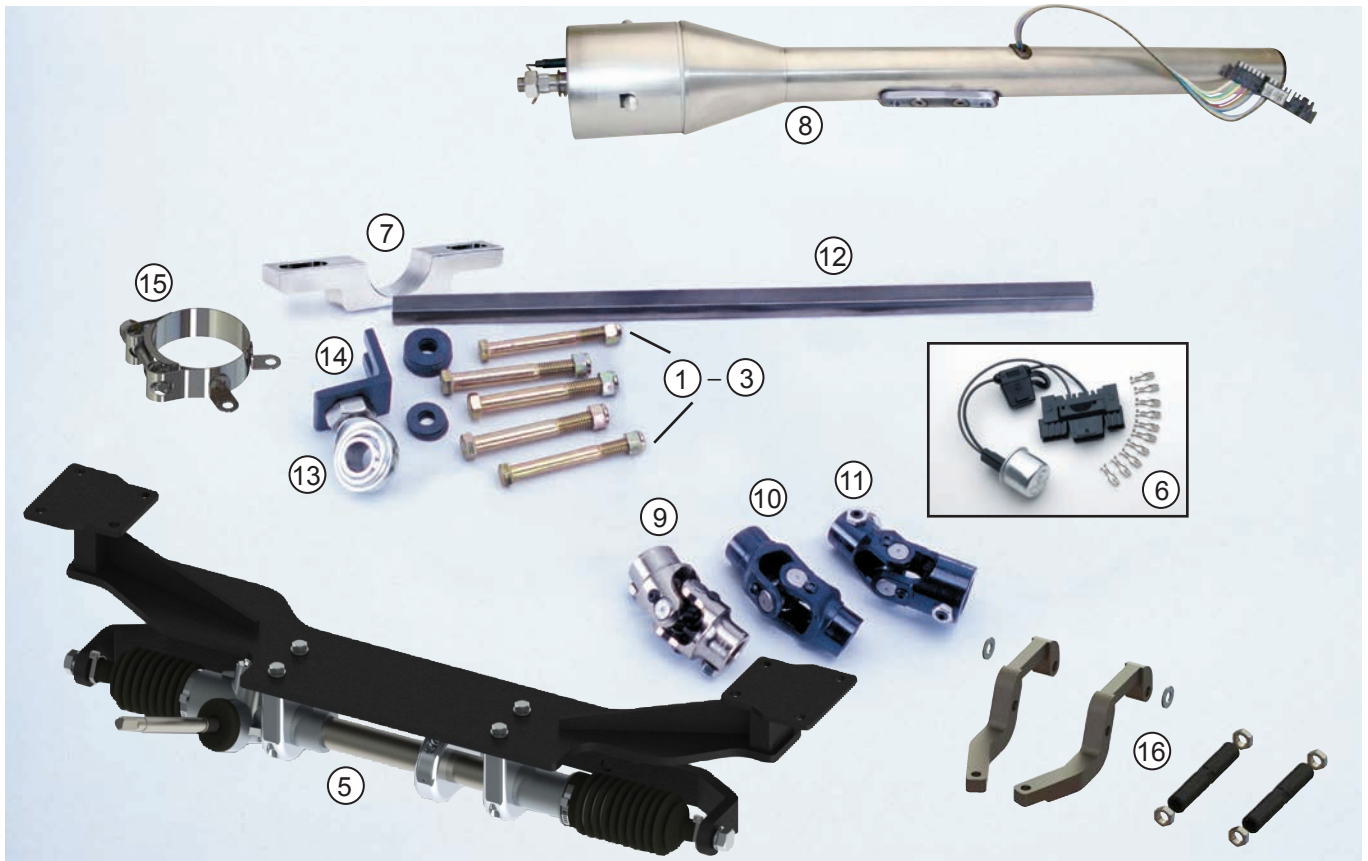

Removing Original Steering System

Before beginning you must first measure the width of your front end from LEFT outer tie rod end zerk to the RIGHT outer tie rod end zerk to determine the overall width of your front end. Write dimension here for further reference _____

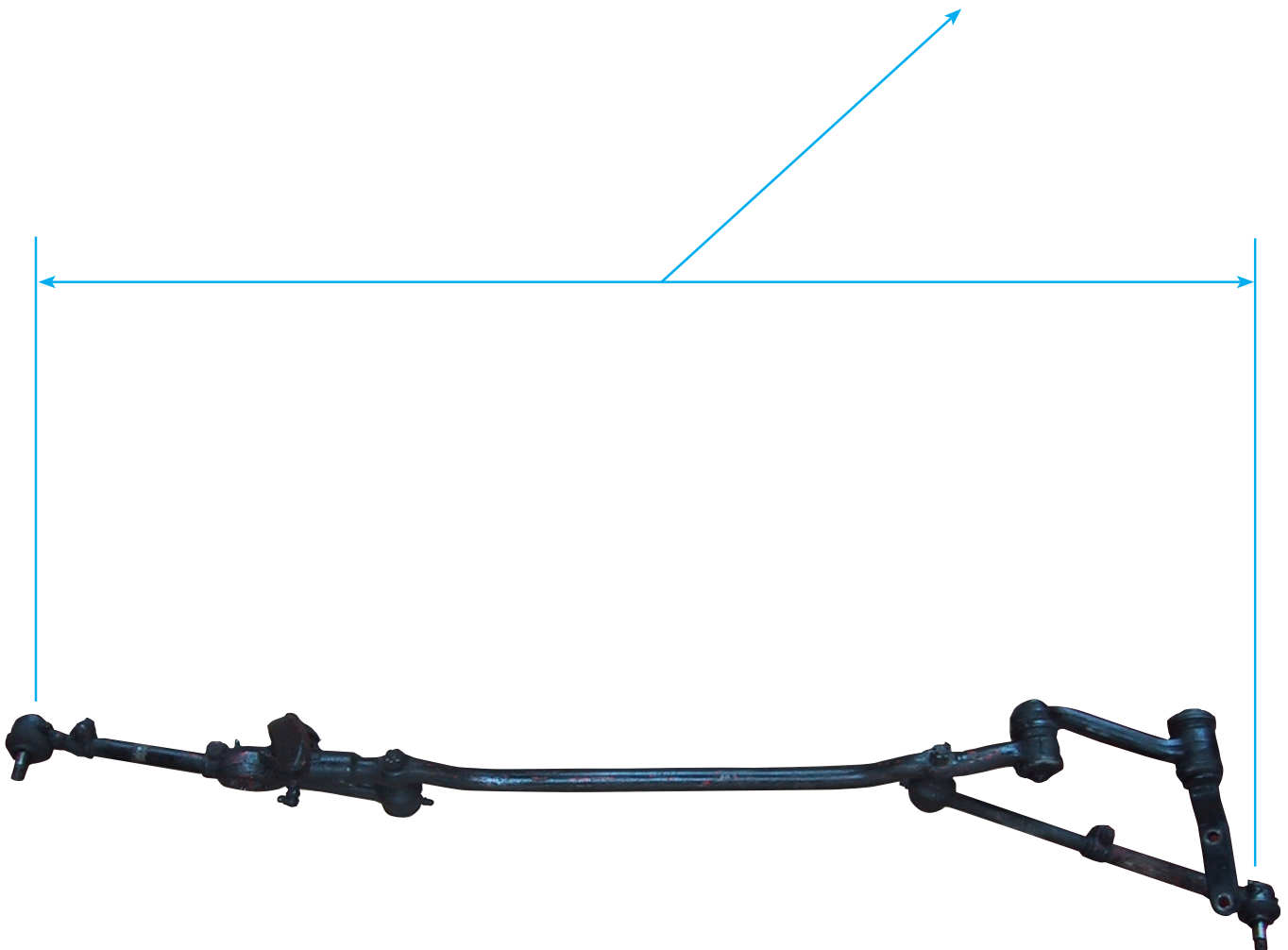

Original Steering System Removal

Color Verification to be completed before disassembly

- Brake Light Switch : _____
- RR Turn Signal : _____
- LR Turn Signal : _____
- Turn Signal Power : _____
- Hazard Power : _____
- RF Turn Signal : _____
- LF Turn Signal : _____
- Horn : _____

Caution: Before disconnecting your original steering column wiring harness please verify each wire color and function on the worksheet at left. Some wire colors may vary from year to year.

- 1) Remove the pitman nut and remove the pitman arm from the steering box.
- 2) Remove the nuts that retain the outer tie rod ends and remove the tie rods from the spindle arm.
- 3) If you have the power assist system, you must also disconnect the slave cylinder from the chassis and remove the mounting bracket.
- 4) Remove the bolts that retain the idler arm and remove the steering linkage from the car (D).
- 5) Remove the two lower steering gear mounting bolts (C) and only loosen the third.
- 6) Disconnect all wiring connectors from column.
- 7) Remove the screws that hold the floor seal in place.
- 8) Using a steering wheel puller remove the steering wheel (A).
- 9) Remove the two nuts that retain column mounting bracket under the dash (B-1).
- 10) Move the front driver's seat to the rear most position and lower the column as far as possible.
- 11) While sitting in the seat, pull the column housing (B) towards you until it is completely off the long pinion shaft.
- 12) Remove the final steering gear mounting bolt and remove the steering box. (C)

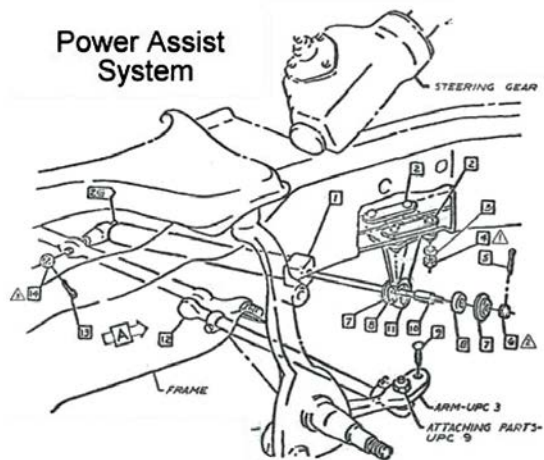
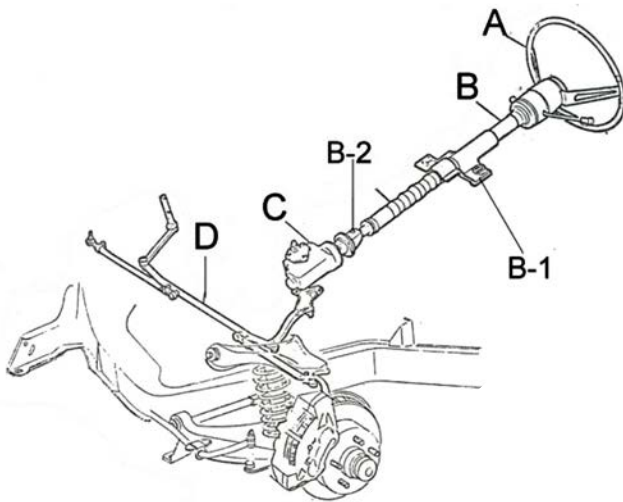

Front Cross Member



Bolt Holes

Factory Spindle Arm



13) Remove front cross member by removing the 4 bolts on the driver's side and the 4 bolts on the passenger's side. (see above)

14) Remove the two bolts that retain the factory front spindle arms to the spindle and remove the arms.

Flaming River Rack and Pinion Cradle Installation

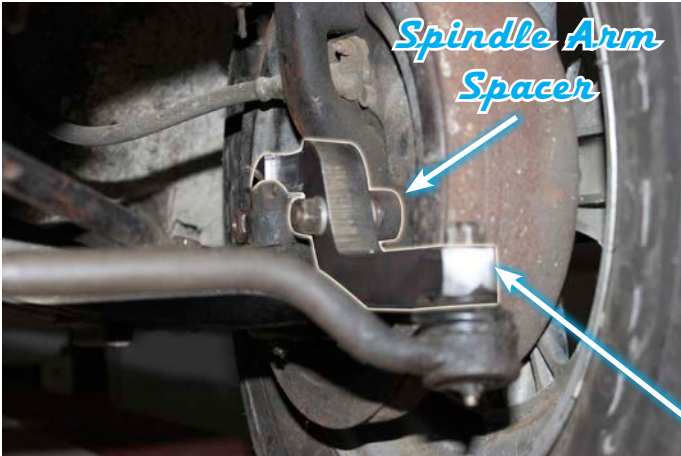

1) Install the new spindle arms provided in the kit facing the front of the car. Install the spacers provided on the front spindle mounting bolt. (See Picture at left)

2) Center the rack by turning it all the way to the left. Next turn the rack all the way to the right, counting the number of turns. Then go back half way.

Spindle Arm

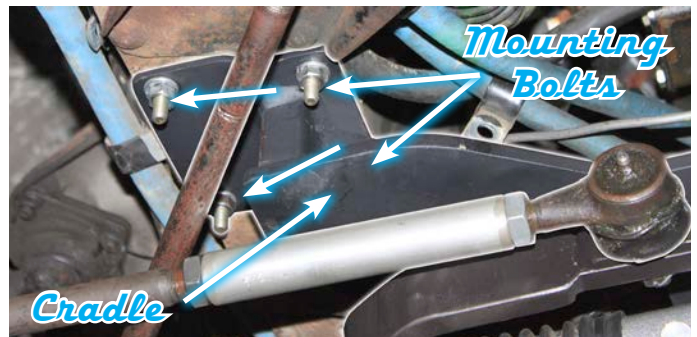
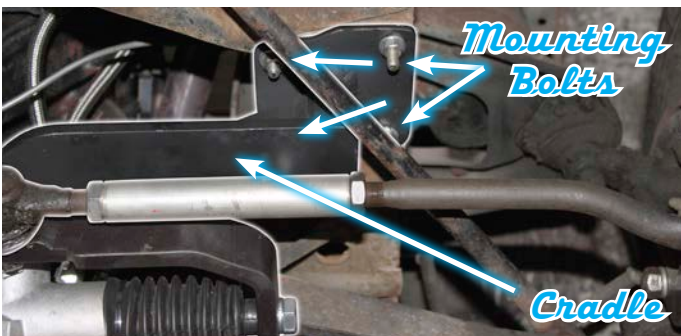

3) **Driver's side:** Hold up the rack mounting cradle where the original cross member was originally and snug the mounting hardware.

4) **Passenger side:** Mount the passenger side of the cradle where the original cross member was and tighten the four 5/16" mounting bolts.

5) Using a torque wrench, tighten all the mounting bolts to 30-40 ft lbs.

6) Install the New Flaming River adjuster sleeves onto the Factory inner tie rod ends. Next, install the outer tie rod ends into the adjuster sleeves and adjust tie rods until the original zerk to zerk measurement taken before disassembly is obtained. _____ Measurement from page 5.

7) To install the inner tie rod ends into the travel bar system and to install the outer tie rod ends into the spindles, you must load the front suspension. Securely placing jack stands under the lower control arms and lowering the car onto the jack stands accomplishes this. Install the outer tie rod ends into the spindle and tighten the castle nuts to 30-40 ft lbs. Make sure to install cotter pins into the castle nut and tie rod end and bend the tabs over for security.



Flaming River Tilt Column Installation

- 1) Slide the floor mount that is included in the kit over the column tube and then slide the original floor seal and floor plate over the column tube.
- 2) Slide the column through the firewall so that the end of the column tube is about a 1/4" past the firewall.
- 3) Using the original under dash mount, mount the column to the dash. Only snug the mounting bolts.
- 4) Set the turn signal arm at the 9 o'clock position; tighten down the mounting bolts to secure the column.
- 5) Fasten the original floor seal to the firewall using the bolts removed earlier.
- 6) Next, slide the column mounting bracket so that the mounting flange is flush against the floor seal plate, and then snug the column mounting bracket to the column tube.
- 7) Fasten the column bracket to the floor seal using the hardware provided. NOTE: The new floor mount assembly can be removed and painted.

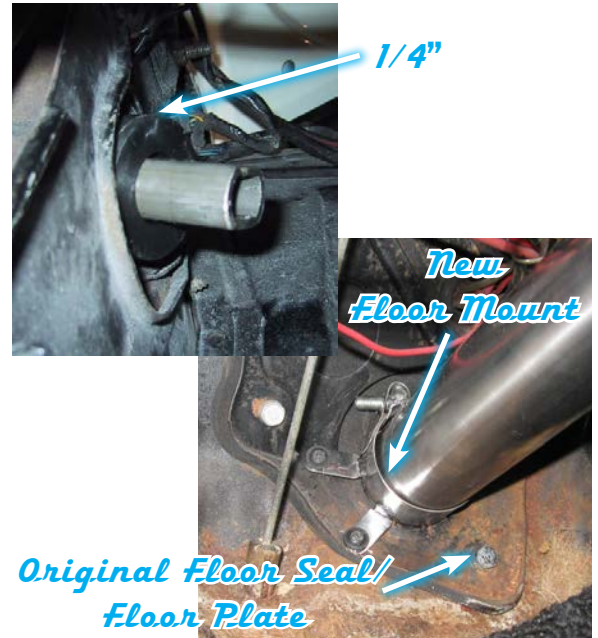

Connecting the Electric System

<u>Function</u>	<u>FR Column</u>	<u>Location</u>	<u>Vehicle Wiring</u>
Horn	Black	G	Brown (Horn Relay)
Lt Front Turn Signal	Light Blue	H	Green/White
Rt Front Turn Signal	Blue	J	White/Black
Hazard	Brown	K	See Note
Turn Signal - Power	Purple	L	Blue
Lt Rear Turn Signal	Yellow	M	Green/Orange
Rt Rear Turn Signal	Green	N	Orange/Blue
Brake Light	White	P	Green

Note: The hazard power wire goes to a 12v power source from the vehicle's fuse panel. This feature will add 4-Way emergency flashers to the car.

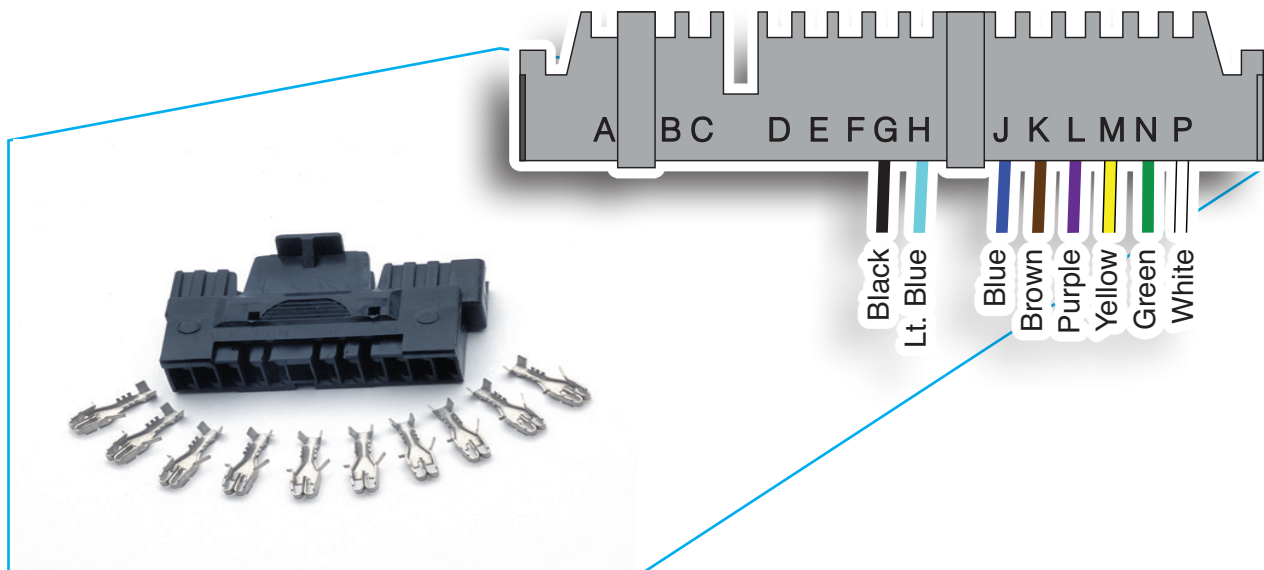

Universal Joint System



Note: For vehicles with small block motors, part number FR50004C coated exhaust headers are available and sold separately for a 2 u-joint setup. If you are using long tube headers or a big block motor, 3 u-joints may be necessary and you must install the support bearing and bracket that is included in this kit.

- 1) Install support-bearing mount onto the rear cradle bolt. (Photo at right). Note: The angle of this mount is set for most applications. Some adjustment may be necessary for the correct angle and u-joint alignment.
- 2) We recommend the use of $\frac{3}{4}$ " dowel rod to mock up the steering shaft to obtain the correct length of the shafts.
- 3) Install your shaft kit and snug each set screw so that it will leave a mark in the shafts.
- 4) Remove shaft and dimple each set screw mark using a $\frac{1}{4}$ " drill bit. (As shown below.)
- 5) Re-install the shafts using red thread locker on the set screw threads. Tighten each setscrew to 25 ft. lbs. Tighten all lock nuts securely. We recommend that you inspect setscrews periodically for tightness.

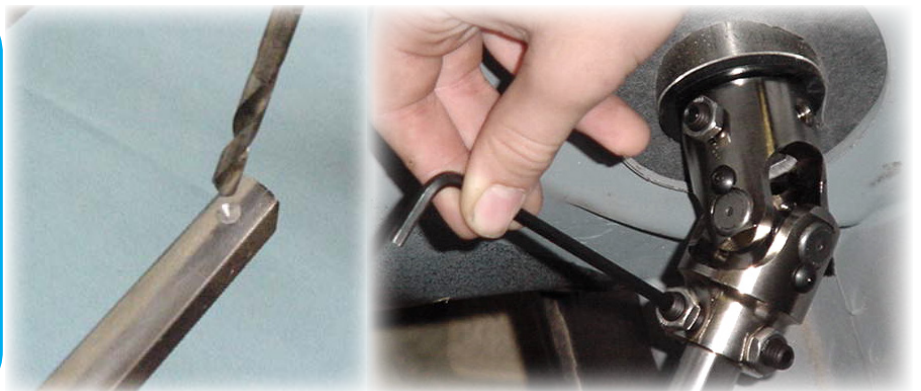
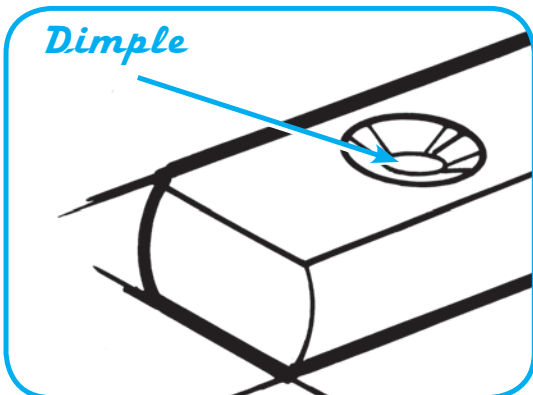
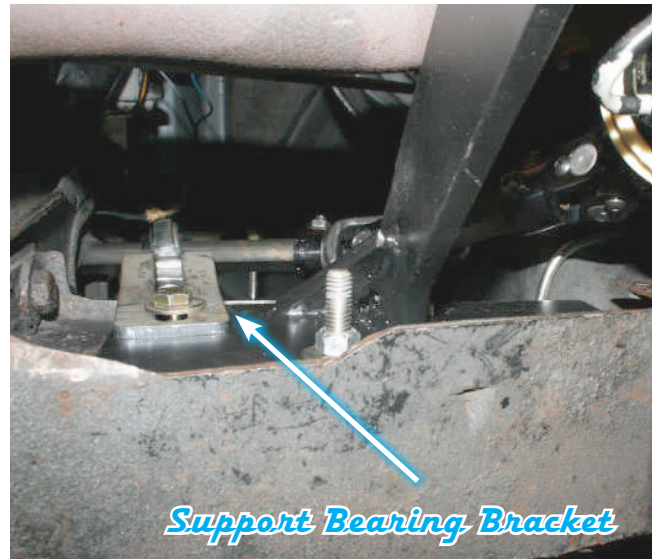

Steering Wheel Installation

1) Install horn contact kit into canceling cam tube and turn to lock.

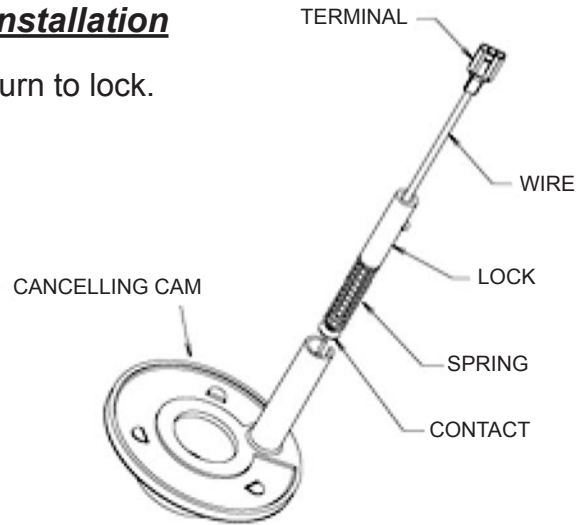
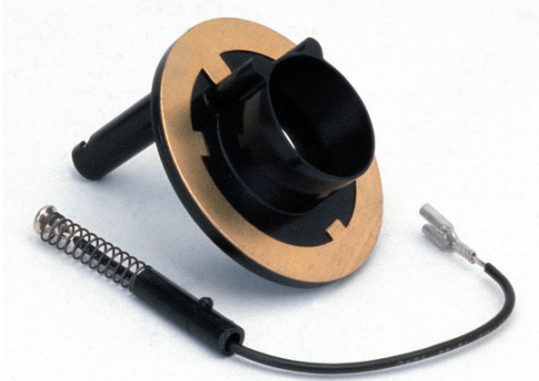

2) Be sure Rack and Pinion is in the center position before starting install of steering wheel. Align steering wheel adapter so that the canceling cam hole is at approx the 11 o'clock position and that one of the steering wheel mounting holes is at the 12 o'clock position. (After 1st test drive, it may be necessary to re-center wheel)

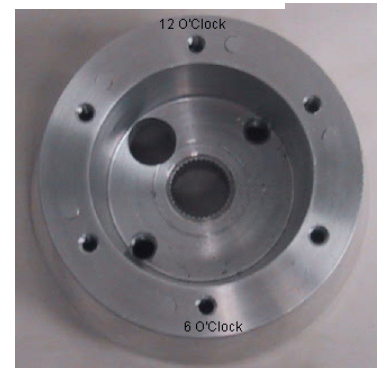
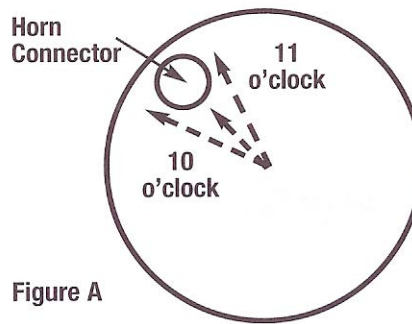

3) To install the wheel adapter run the horn contact wire through the hole for the canceling cam and place the adapter on to the splined column shaft.

4) Tighten the adapter-retaining nut securely until the adapter is approximately 1/16" away from the column shroud. (Overtightening can cause wheel to rub)

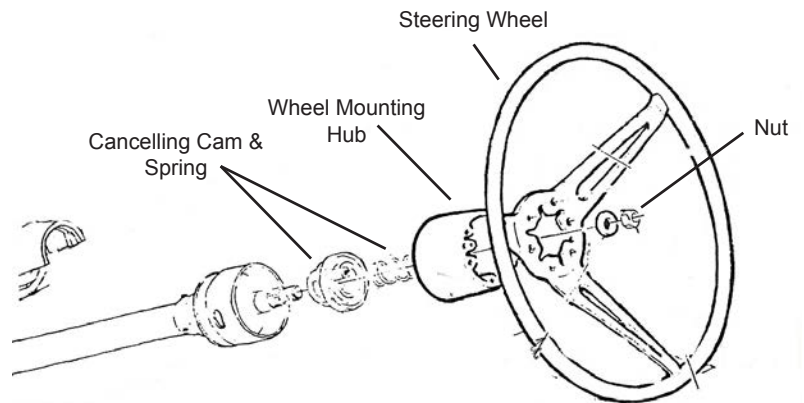

Flaming River Column Wiring

<u>Wiring Circuit</u>	<u>Pin Location</u>	<u>Column Wiring Color</u>
Brake Light Switch	P	White
Right Rear Turn Signal	N	Dark Green
Left Rear Turn Signal	M	Yellow
Turn Signal Power	L	Purple
Hazard Power	K	Brown
Right Front Turn Signal	J	Dark Blue
Left Front Turn Signal	H	Light Blue
Horn	G	Black

Color Verification to be completed before disassembly

- Brake Light Switch : _____
- RR Turn Signal : _____
- LR Turn Signal : _____
- Turn Signal Power : _____
- Hazard Power : _____
- RF Turn Signal : _____
- LF Turn Signal : _____
- Horn : _____

FR1613 Big Block Chevy Power Steering Pump Bracket

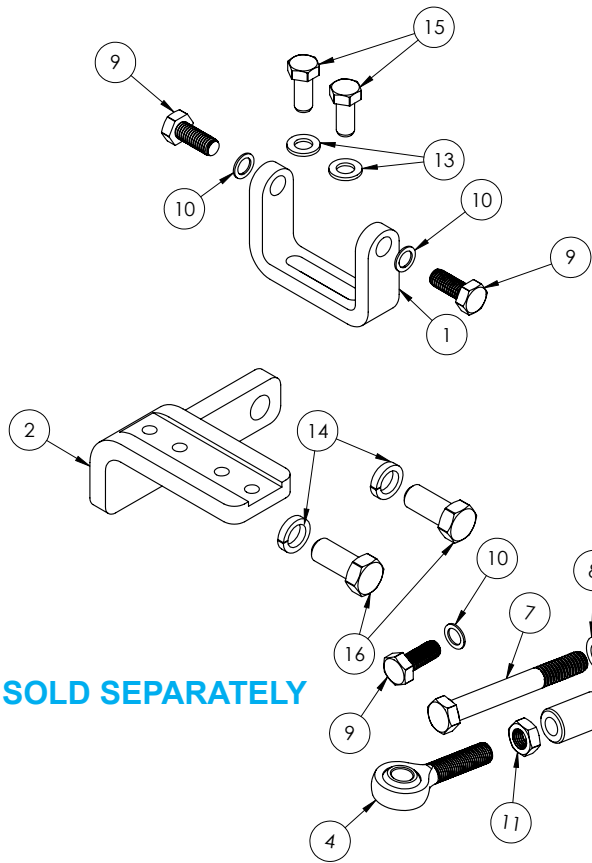

ITEM NO.	QTY.	PART NUMBER	DESCRIPTION
1	1	100633	BRACKET, MOUNT PUMP PS
2	1	100649	BRACKET, MOUNT PUMP-MOTOR SB
3	1	100667	HEIM JOINT, END ROD 3/8-24 RH
4	1	100668	HEIM JOINT, END ROD 3/8-24 LH
5	1	100720	SPACER, ADJ 0.62 X 2.52 W/ 3/8-24 RH-LH
6	1	100721	SPACER, 0.392 X 0.62 X 1.00 ALUM
7	1	100722	BOLT, 3/8-16 X 3.00 HEX HD GR8
8	1	100723	WASHER, FLAT 0.39 X 0.62 X .05
9	3	100724	BOLT, M8 X 1.25 X 20 HEX HD GR10.9
10	3	100725	WASHER, FLAT 0.32 X 0.47 X .04
11	1	100728	NUT, 3/8-24 JAM LH
12	1	100729	NUT, 3/8-24 JAM RH
13	2	100730	WASHER, FLAT 0.32 X 0.57 X .06
14	2	100732	WASHER, LOCK SPLIT 7/16 HIGH COLLAR
15	2	102725	SCREW, 5/16-18 X .75 HEX HD GR8
16	2	BOLT-7/16-14X1	BOLT, 7/16-14 X 1.00 HEX GR8

SOLD SEPARATELY



800 Poertner Dr., Berea, Ohio 44017 • 1-800-648-8022

Power Steering Pump Installation/Big Block Chevy



Install L-shaped bracket (2) on engine with bolts (16) and lockwashers (14) supplied



Install pump bracket (1) to L-shaped bracket (2) with bolts (15) and washers (13) supplied



Install pump to bracket (1) using bolts (9) and washers (10) supplied



Install adjuster to pump using bolt (9) and washer (10) supplied



Remove upper water pump bolt. Install spacer (6) and adjuster with bolt (7) and washer (8) supplied

FR1612 Small Block Chevy Power Steering Pump Bracket

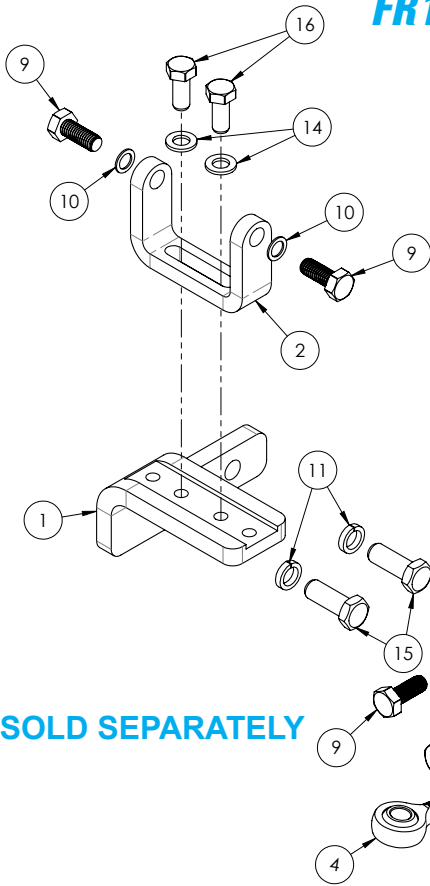

ITEM NO.	QTY.	PART NUMBER	DESCRIPTION
1	1	100632	BRACKET, MOUNT PUMP-MOTOR SB
2	1	100633	BRACKET, MOUNT PUMP PS
3	1	100667	HEIM JOINT, END ROD 3/8-24 RH
4	1	100668	HEIM JOINT, END ROD 3/8-24 LH
5	1	100720	SPACER, ADJ 0.62 X 2.52 W/ 3/8-24 RH-LH
6	1	100721	SPACER, 0.392 X 0.62 X 1.00 ALUM
7	1	100722	BOLT, 3/8-16 X 3.00 HEX HD GR8
8	1	100723	WASHER, FLAT 0.39 X 0.62 X .05
9	3	100724	BOLT, M8 X 1.25 X 20 HEX HD GR10.9
10	3	100725	WASHER, FLAT 0.32 X 0.47 X .04
11	2	100726	WASHER, LOCK SPLIT 3/8 HIGH COLLAR
12	1	100728	NUT, 3/8-24 JAM LH
13	1	100729	NUT, 3/8-24 JAM RH
14	2	100730	WASHER, FLAT 0.32 X 0.57 X .06
15	2	100779	SCREW, 3/8-16 X 1.00 HEX HD GR8
16	2	102725	SCREW, 5/16-18 X .75 HEX HD GR8

SOLD SEPARATELY



800 Poertner Dr., Berea, Ohio 44017 • 1-800-648-8022

Power Steering Pump Installation/Small Block Chevy



Install L-shaped bracket (1) on engine with bolts (15) and lockwashers (11) supplied



Install pump bracket (2) to L-shaped bracket (1) with bolts (16) and washers (14) supplied



Install pump to bracket (2) using bolts (9) and washers (10) supplied



Install adjuster to pump using bolt (9) and washer (10) supplied



Remove upper water pump bolt. Install spacer (6) and adjuster with bolt (7) and washer (8) supplied



Instruction Bulletin #1021

Correct Bleeding Procedure for Flaming River Power Rack & Pinion Systems.

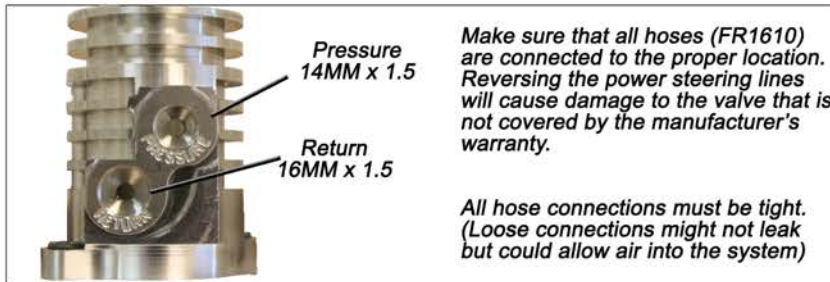

Make sure that all hoses (FR1610) are connected to the proper location. Reversing the power steering lines will cause damage to the valve that is not covered by the manufacturer's warranty.

All hose connections must be tight. (Loose connections might not leak but could allow air into the system)

Important

***** Power Steering Fluid*****
Use clean, new power steering fluid only.

- 1) Turn Ignition Off
- 2) Raise front wheels off the ground.
- 3) Turn the steering wheel full left.
- 4) Fill fluid level to "Full Cold" level or if using remote reservoir 1" over inner tube.
- 5) With assistant checking fluid level and condition, turn steering wheel lock to lock at least 20 times.
- 6) While turning wheels check fluid level constantly.
- 7) Start engine. With engine idling, maintain fluid level. Reinstall cap.
- 8) Return wheels to center. Lower front wheels to the ground.
- 9) Keep engine running for two (2) minutes.
- 10) Turn steering wheel in both directions.
- 11) If all proper conditions apply, bleeding is complete.
- 12) If any problem remains see "Special Conditions".

Verify:
Smooth power assist
Noiseless operation
Proper fluid level
No system leaks
Proper fluid condition
No bubbles, no foam,
no discoloration.

Note: On systems with long return lines or fluid coolers, turn steering wheel lock to lock at least 40 times.

Trapped air may cause fluid to overflow. Thoroughly clean spilled fluid to allow for leak check.

Note: No bubbles are allowed.

For any sign of bubbles, recheck connections then repeat step 5.

Special Conditions:



- Foam or bubbles in fluid
- Fluid must be completely free of bubbles. In step 5, be alert to periodic bubbles that could indicate a loose connection or leaky O-Ring seal in either the return hose or pressure hose.
- Discolored fluid (milky, opaque, or light tan color)

Switch ignition off. Wait two (2) minutes. Recheck hose connections. Repeat steps 7-10. If condition still exists, replace and check a possible cause:

- Return hose clamps
- Return hose o-ring
- Pressure hose o-ring
- Gear cylinder line o-rings

Fill system and repeat bleed procedure for each possible cause. Repeat steps 7-10 to verify whether noise has been eliminated.



- Pump whine or groan
- With engine running, recheck hoses for possible contact with frame body or engine. If no contact is found, follow either method below to cool down fluid and re-pressurize system.

Method 1:
Normal Cool Down

Switch engine off.
Wait for system to cool.
Install reservoir cap.

Method 2:
Partial Fluid Replacement

Switch engine off. Use a Suction device to remove fluid from the reservoir. Refill with cool, clean fluid. Install Reservoir cap.

After either method of cooling, start engine and allow engine to reach normal operating temperature. If noise persists, remove and replace power steering pump. Repeat bleed procedure following pump replacement.

WARRANTY DISCLAIMER:

Flaming River® warrants its products to be free from defects in material and workmanship for a period of one (1) year after the date of purchase. It is the customer's responsibility to determine the suitability of a given Flaming River® product for the customer's uses. Use qualified chassis specialists for the installation of all steering related components. Be aware that the installation of certain Flaming River® products may adversely impact a manufacturer's warranty with respect to certain vehicles and other manufactured goods. Flaming River will repair or replace any product found to be defective in material or workmanship. Improper installation, abuse, racing and/or modification VOID WARRANTY. Flaming River® is not responsible for any labor costs associated with any warranty.

Additional Installation Accessories (Sold Separately)

SMALL BLOCK EXHAUST HEADERS
(May be necessary with power kits)



FR50004C
62-67 Nova



Power Steering Hose Kit FR1610

FR1610 Hose Kit Routing

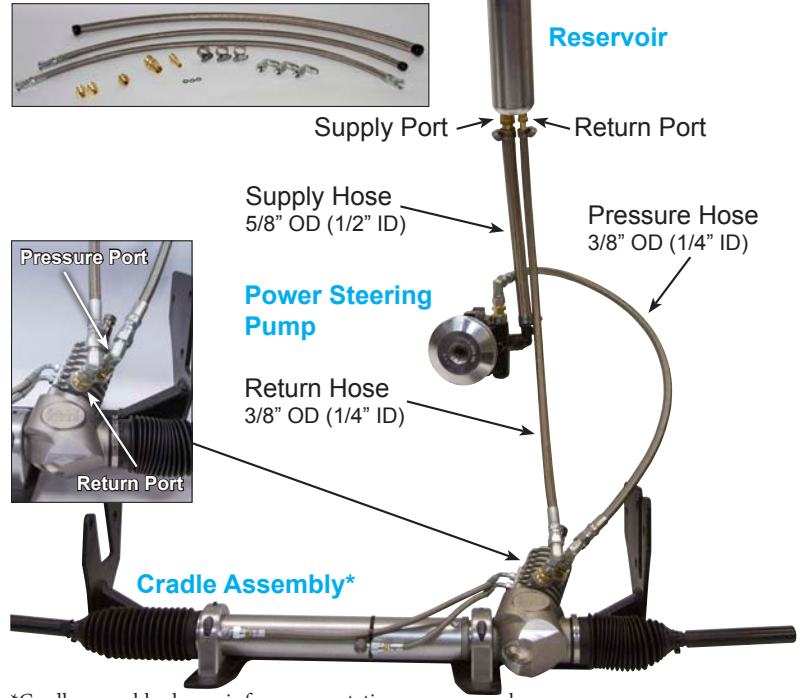

*Cradle assembly shown is for representation purposes only



If not using our hose kit, we recommend purchasing the FR1632 Pressure and Return fittings kit. If you have any questions regarding connecting alternate hose kit to Flaming River Cradle Assembly, please call 1-800-648-8022.

In order to ensure the best customer experience possible, we've created a Customer Satisfaction Survey to gather important feedback about different facets of our business. We would appreciate it if you could please take a couple of minutes to fill out this survey about your experience.

The results of the survey will be used to improve and gather feedback about customer service, technical and sales support, order processing and fulfillment, manufacturing, and new product development.

Upon completing the survey, you will be issued a discount coupon code to be used on your next online purchase at www.flamingriver.com/survey.



Flaming River Ind.
800 Poertner Dr
Berea, OH 44017
800-648-8022