



Flaming River Ind.
800 Poertner Dr
Berea, OH 44017
800-648-8022

*55-57 Chevy
Big Block & Small Block
Rack and Pinion
Conversion Kit*



For safety, disconnect battery cables and ensure that vehicle is properly supported by jack stands.

NOTE: Hoses (FR1610), Big Block Pump Mounting Bracket (FR1613) sold separately and not included in this kit.

68-69 Camaro Outer Tie Rod Ends Part # ES381RL must be used with this rack and pinion kit. (Must purchase separately from local or online auto parts supplier)

Before paint or powder coating of the rack and pinion cradle system we recommend that you prefit the system to ensure proper fit.

Kit Inventory	pg 3-4
Original System Removal.....	pg 5-8
Rack and Cradle Installation	pg 9
Universal Joint and Steering Shaft Installation	pg 10
Tilt Column Installation	pg 11-13
Electrical System Notes	pg 13
Power Steering Pump Installation	pg 14
Power Steering Bleeding Procedure	pg 15

Note: A front end alignment is necessary after installation.

Hazard Kit Part Numbers:

FR20115 1955 Chevy

FR20116 1956 Chevy

FR20117 1957 Chevy

Note: Hoses (FR1610) and Hazard Wiring Kits are sold separately and are not included in this kit.

Note:**** The use of Flaming River Small Block Headers may be necessary with use of the Power Rack and Pinion System.

**** Part No. FR50001 (Uncoated) or FR50001C (Coated)

Note: Flaming River recommends that you use synthetic or high grade power steering fluid.

WARRANTY DISCLAIMER: Flaming River's® Limited Warranty

Flaming River® warrants its products to be free from defects in material and workmanship for a period of one (1) year after the date of purchase, except that: All steering columns are warranted for a period of three (3) years from the date of purchase. The Big Switch (part number FR1005) is warranted for a period of three (3) years from the date of purchase, provided that it is not mounted with a steel bracket and provided further that it is adequately protected from environmental conditions. All electrical products other than the Big Switch are warranted for a period of ninety (90) days from the date of purchase. Flaming River's® warranty liability is limited to the replacement of defective products. Flaming River® is not liable for any labor costs associated with any warranty claim, or for any incidental or consequential damages. Improper installation, abuse, racing, and/or modification of the products voids this warranty. No warranty of merchantability or fitness for a particular purpose is made by Flaming River® with respect to any of its products. Warnings and Recommendations It is the customer's responsibility to determine the suitability of a given Flaming River® product for the customer's uses. Likewise, it is the customer's responsibility to install a Flaming River® product. Contact the vehicle manufacturer whenever installing a switch to confirm the appropriateness of using such a switch and the recommended placement of the switch on the vehicle. Use qualified chassis specialists for the installation of all steering related components. Be aware that the installation of certain Flaming River® products may adversely impact a manufacturer's warranty with respect to certain vehicles and other manufactured goods. Flaming River will repair or replace any product found to be defective in material or workmanship. Improper installation, abuse, racing and/or modification VOID WARRANTY. Flaming River® is not responsible for any labor costs associated with any warranty.

Item No.	Part No.	Description	Qty	Power/Manual Kit
1	100234	Installation Hardware Kit	1	
2	102213	Power Rack and Mounting Cradle Assembly	1	Power Kit Only
3	BK10400	Support Bearing Bracket	1	
4	FR1612	Power Steering Pump Bracket	1	Power Kit Only
5	FR1614	Power Steering Fluid Reservoir	1	Power Kit Only
6	FR1810	Zinc 3/4" Support Bearing	1	
7	FR1850	18" Length of 3/4" DD Shaft	1	
8	FR1920	3/4" DD X 3/4" DD Universal Joint (Center)	1	
9	FR1934	1" DD X 3/4" DD Universal Joint (Column)	1	
10	FR1969	FR Power X 3/4" DD Universal Joint (Rack)	1	Power Kit Only
11	FR20101-57	Tri-Five Swivel Floor Mount	1	
12	FR20118	Female Wiring Connector Kit	1	
13	FRDMDC	FR Domed Decal	1	
14	FRPMP5B-V	Power Steering Pump w/ V-Belt Pulley	1	Power Kit Only

Column Varies with Part Number Ordered

FR20005 (55-56 Floor Shift) In kit FR307KTPW
 FR20023 (55-56 Column Shift) In kit FR309KTPW
 FR20005-57 (57 Floor Shift) In kit FR308KTPW
 FR20023-57 (57 Column Shift) In kit FR311KTPW



1955-56
Floor
Shift

1955-56
Column
Shift

1957
Column
Shift

1957
Floor
Shift

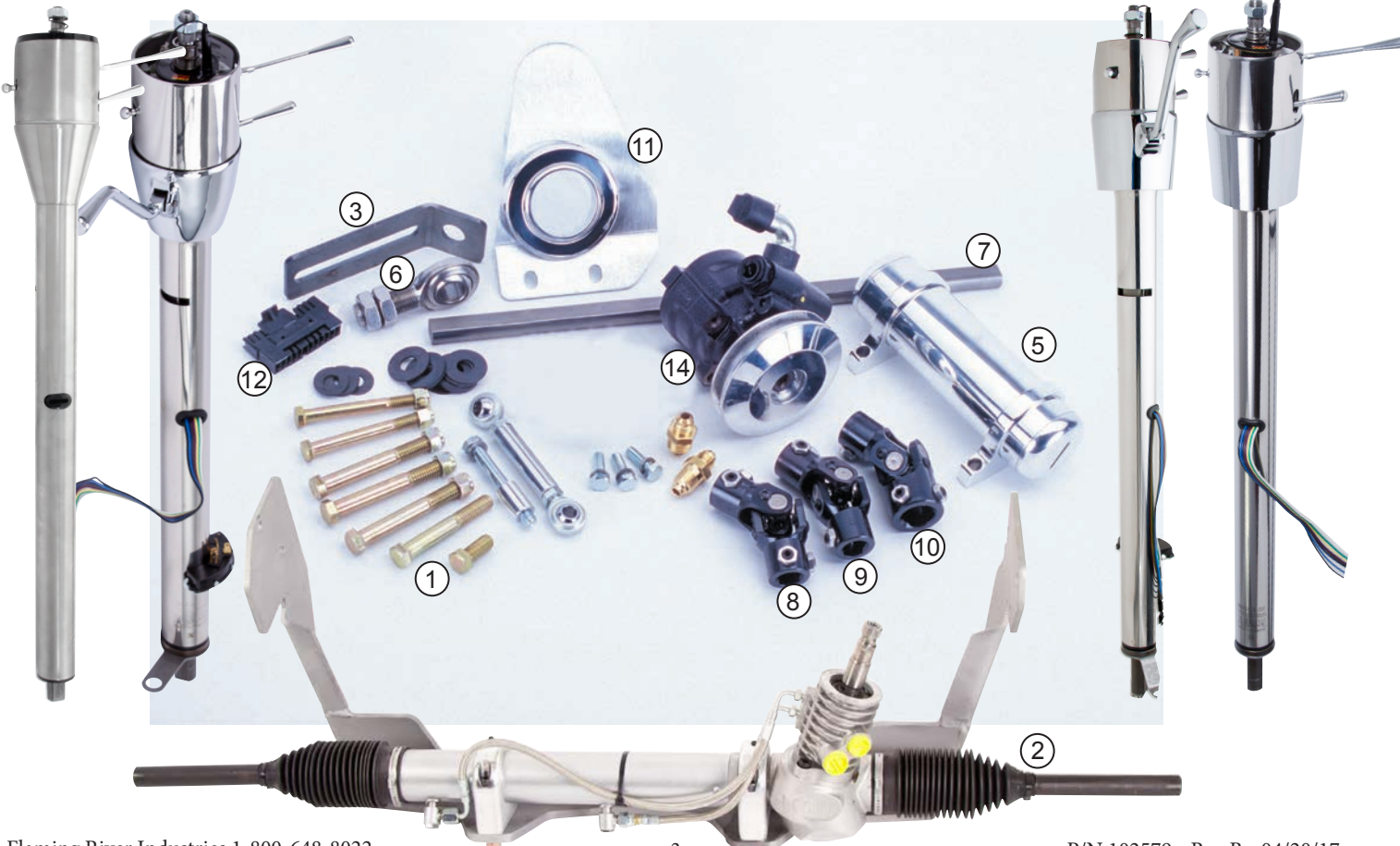

Item No.	Part No.	Description	Qty	Power/Manual Kit
1	100233	Installation Hardware Kit	1	
2	BK10400	Support Bearing Bracket	1	
3	FR1507-3Q-9	Manual Rack and Pinion Assembly	1	Manual Kit Only
4	FR1507C	Rack Mounting Clamp w/ Bushing	1	Manual Kit Only
5	FR1810	Zinc 3/4" Support Bearing	1	
6	FR1850	18" Length of 3/4" DD Shaft	1	
7	FR1920	3/4" DD X 3/4" DD Universal Joint (Center)	1	
8	FR1924	9/16"-26 X 3/4" DD Universal Joint (Rack)	1	Manual Kit Only
9	FR1934	1" DD X 3/4" DD Universal Joint (Column)	1	
10	FR20101-57	Tri-Five Swivel Floor Mount	1	
11	FR20118	Female Wiring Connector Kit	1	
12	FRDMDCL	FR Domed Decal	1	
13	FRTRIMC1	Rack Mounting Cradle	1	Manual Kit Only

Column Varies with Part Number Ordered

FR20005 (55-56 Floor Shift) In kit FR306KT
 FR20023 (55-56 Column Shift) In kit FR309KT
 FR20005-57 (57 Floor Shift) In kit FR308KT
 FR20023-57 (57 Column Shift) In kit FR310KT

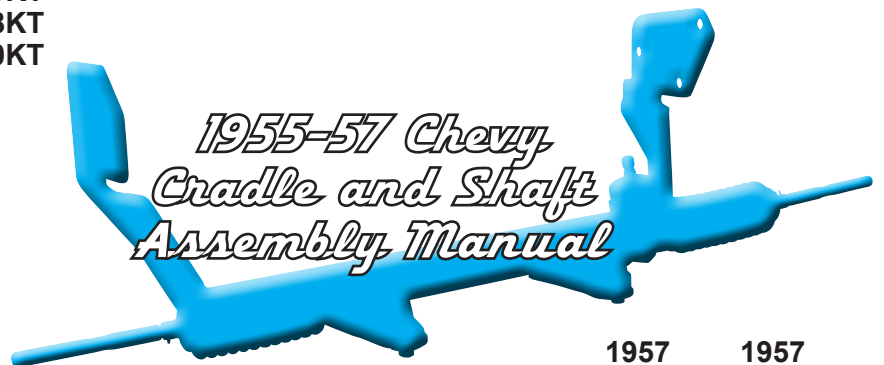

1955-56
Floor
Shift

1955-56
Column
Shift

1957
Column
Shift

1957
Floor
Shift

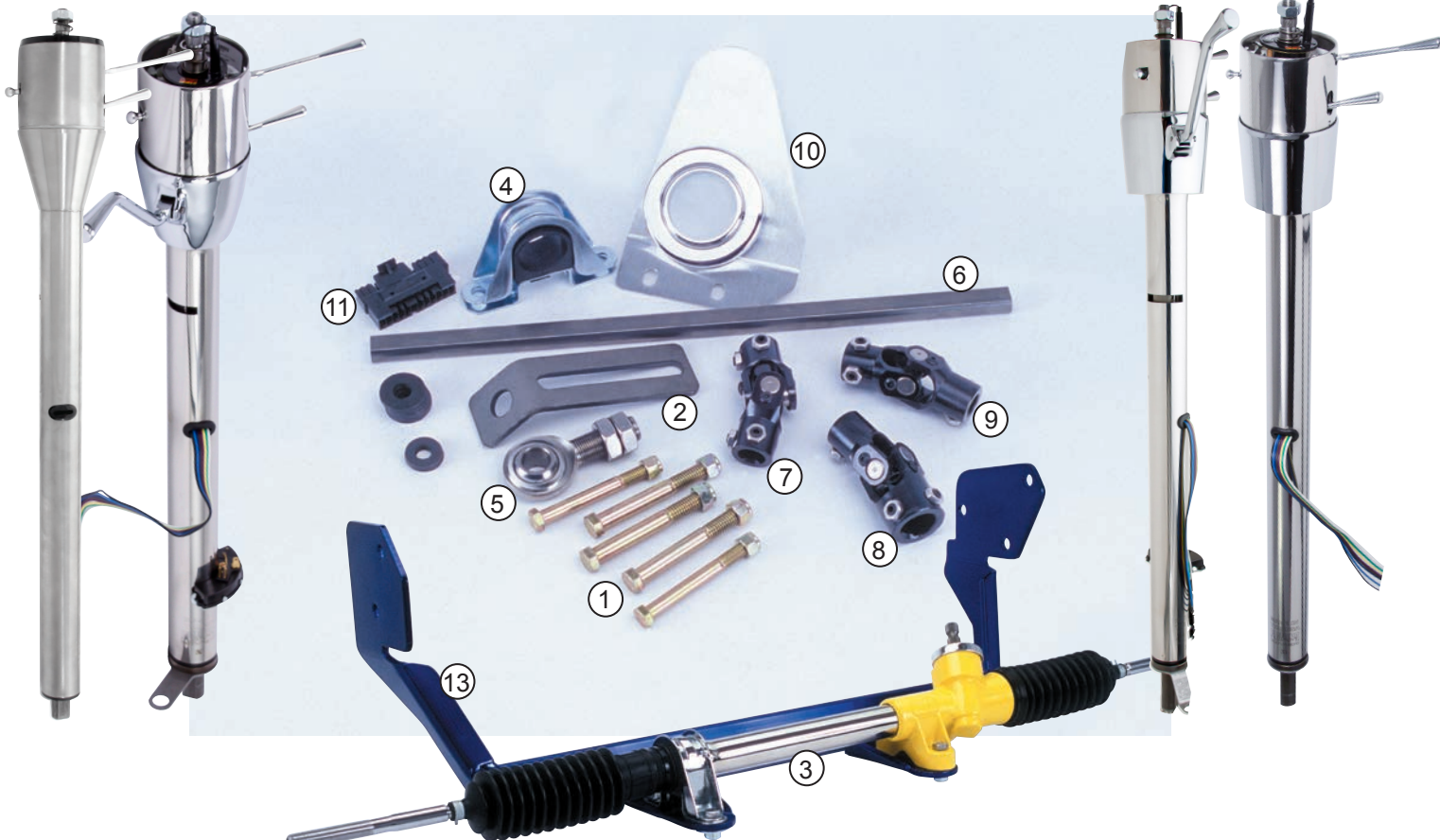

Removing Original Steering System

Before beginning you must first measure the width of your front end from LEFT outer tie rod end zerk to the RIGHT outer tie rod end zerk to determine the overall width of your front end. Write dimension here for further reference _____

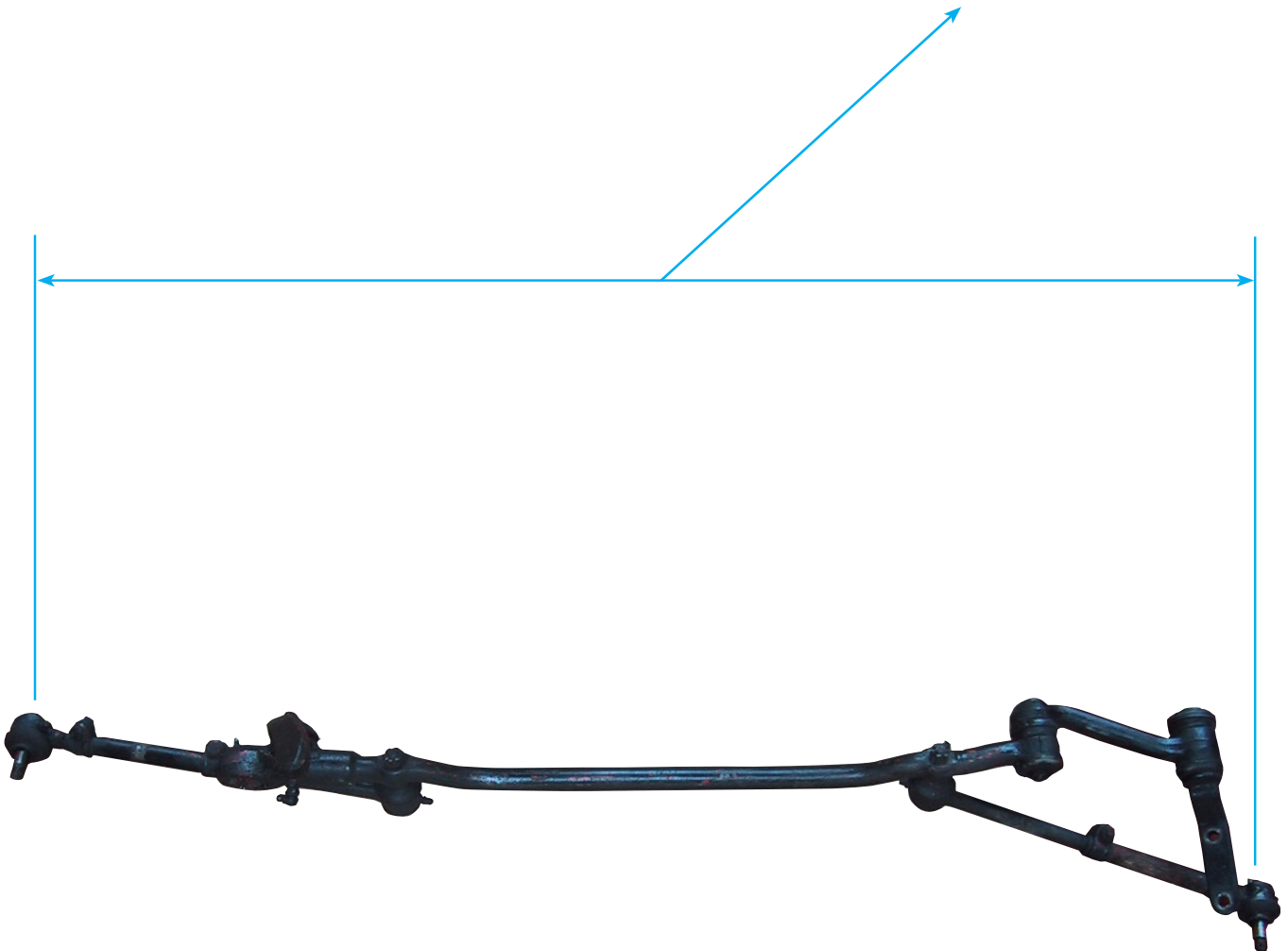

Original System Removal

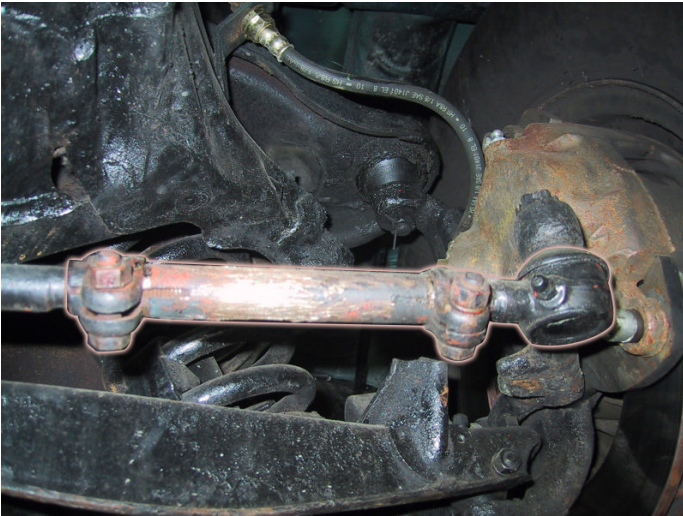

1) Begin by removing the outer tie rod ends from the spindles. This is done by removing the cotter pin and castle nut and separating the tie rod end from the spindle using a pickle fork.



2) Remove the nut that retains the pitman arm to the sector shaft of the steering gear box.

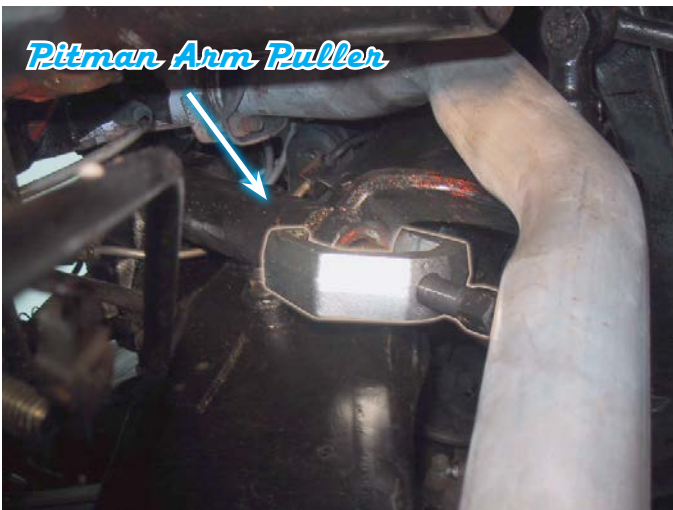

3) Using a pitman arm puller, remove the pitman arm from the steering gear box.



4) Remove the two (2) bolts that hold the idler arm to the frame rail.



5) Remove the entire steering linkage assembly from the car.

Original System Removal (Con't)

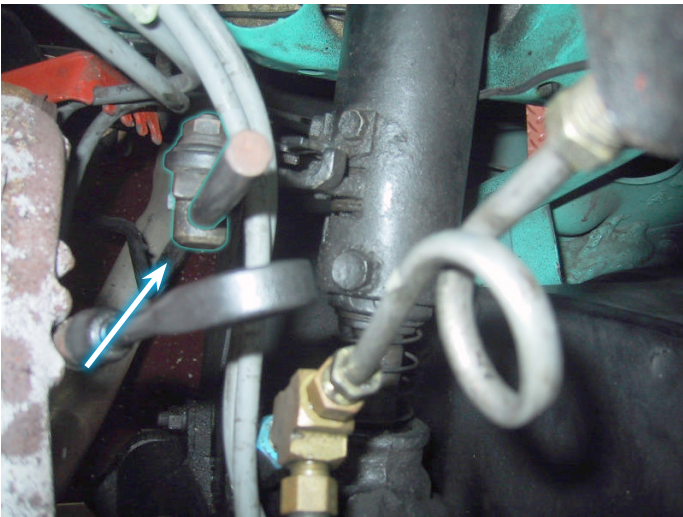

6) On column shift columns, disconnect the shift linkage from the column.

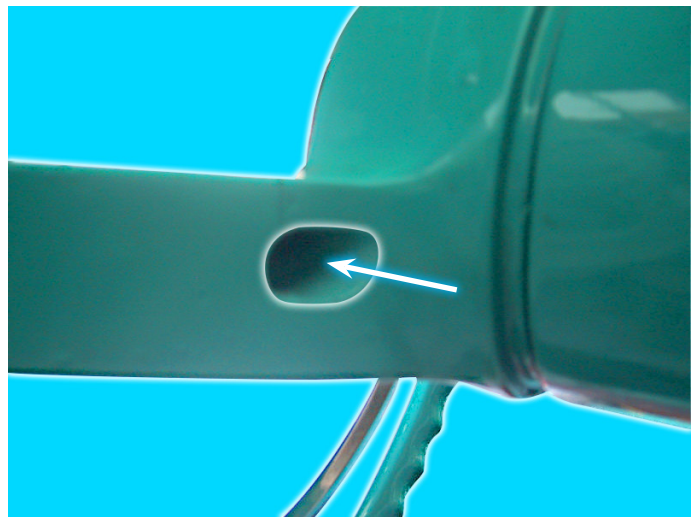

7) Remove the two (2) screws from the back side of the steering wheel.

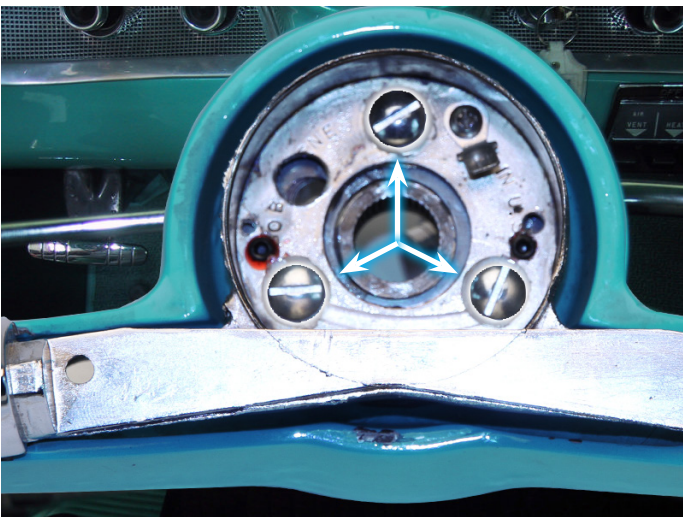

8) Remove the three (3) screws that hold the horn ring to the steering wheel and the wheel retaining nut.

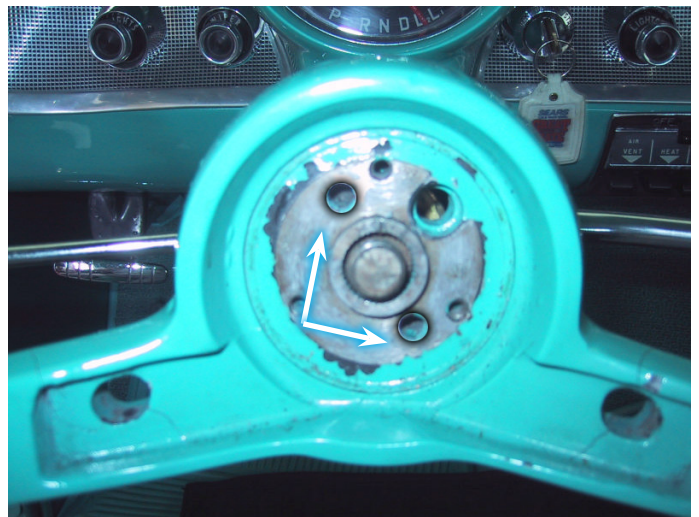

9) Using the two holes and a steering wheel puller, remove the wheel from the column.



10) Remove the lower dash shroud by removing the one (1) screw in the middle.

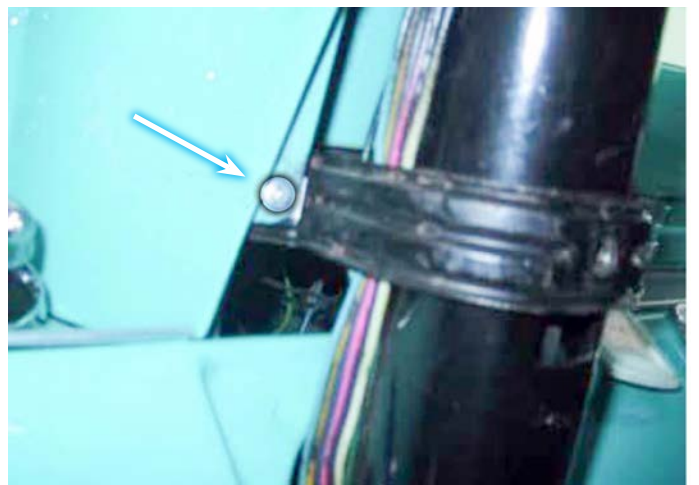

11) Remove the two (2) screws that hold the lower dash shroud mount in place, and then remove the mount.

Original System Removal (Con't)

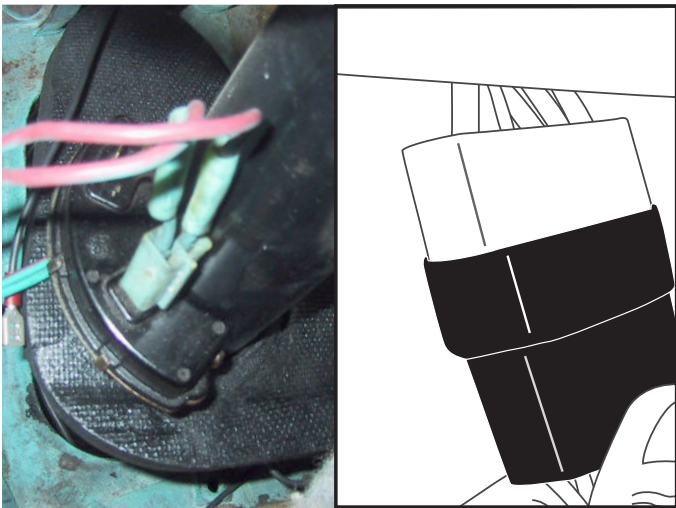

Color Verification to be completed before disassembly

- Brake Light Switch : _____
- RR Turn Signal : _____
- LR Turn Signal : _____
- Turn Signal Power : _____
- Hazard Power : _____
- RF Turn Signal : _____
- LF Turn Signal : _____
- Horn : _____

12) Remove the column wiring for the turn signal and the neutral safety switch (column shift only) from under the dash.

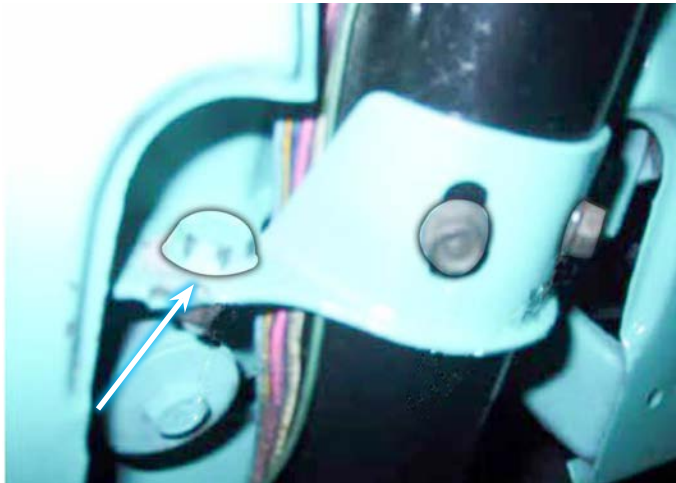

13) Remove the two bolts that retain the column mount to the dash.



14) Remove the factory floor seal.

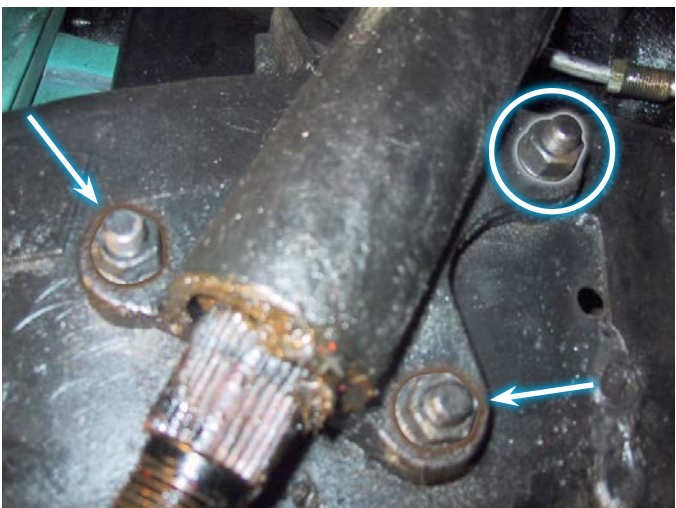

15) Remove the bolts with the arrows and loosen the bolt that is circled



16) Pivot the column downward and remove the column from the box shaft. Then, remove the box from the car.

Flaming River Rack and Pinion Cradle Installation

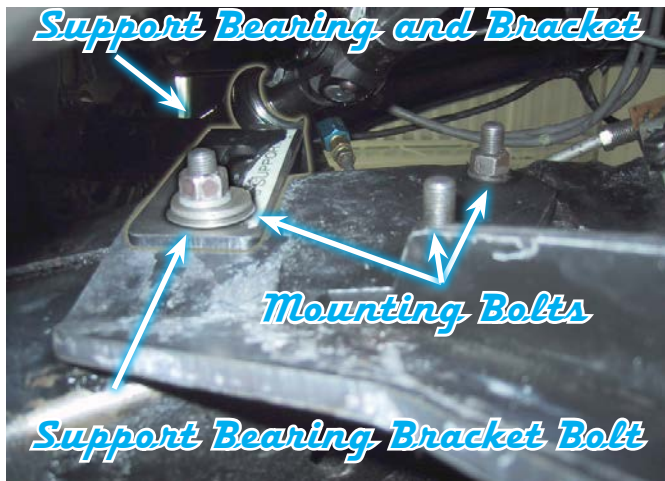

Driver's Side

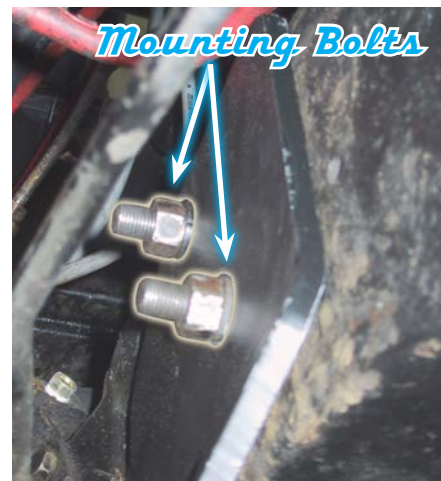

Passenger's Side

1) Slide the Rack and Pinion Cradle Assembly in-between the frame rails and insert the three (3) mounting bolts on the driver's side and the two (2) on the passenger side. Install support bearing and bracket on the rear bolt (above left). Tighten mounting hardware to 40- 45ft lbs.

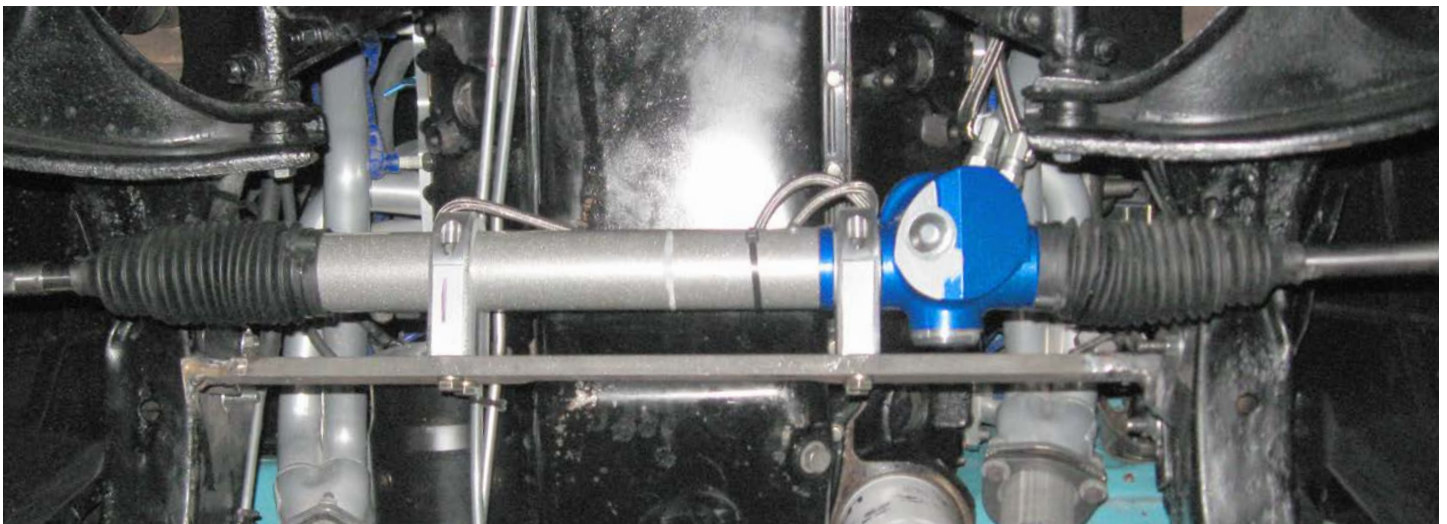

Cradle Installed

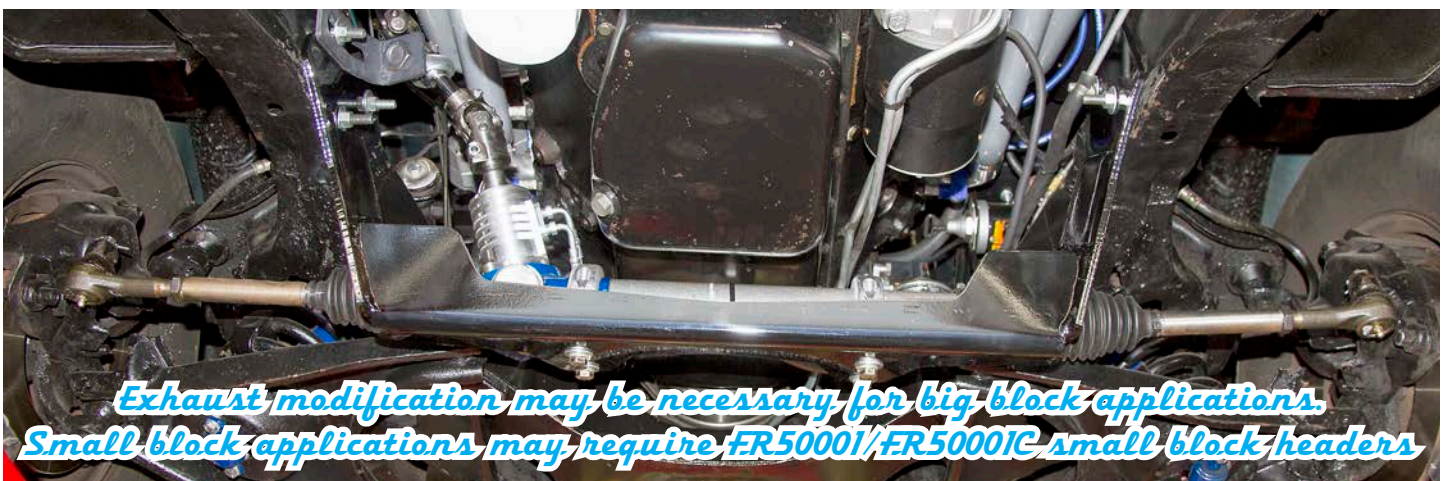

Universal Joint System

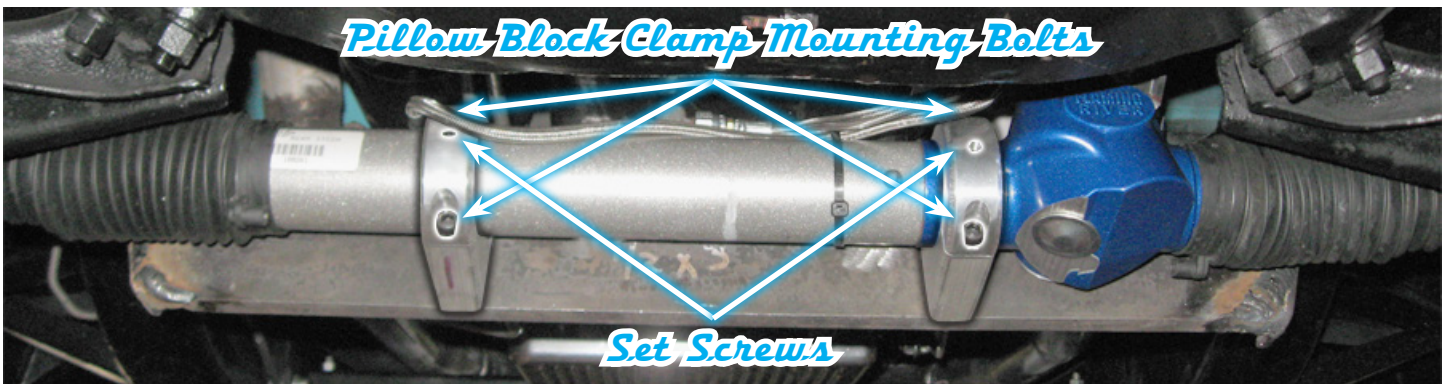

1) The Flaming River Power Rack and Pinion Cradle Assembly comes preassembled from the factory. However, you may need to adjust the pinion angle for proper u-joint alignment. First, loosen the set screws on the pillow block clamps. Next, loosen the (4) four pillow block clamp mounting bolts. Then adjust your pinion angle. Once your pinion angle is set, tighten the (4) four pillow block mounting clamp bolts and then the set screws.

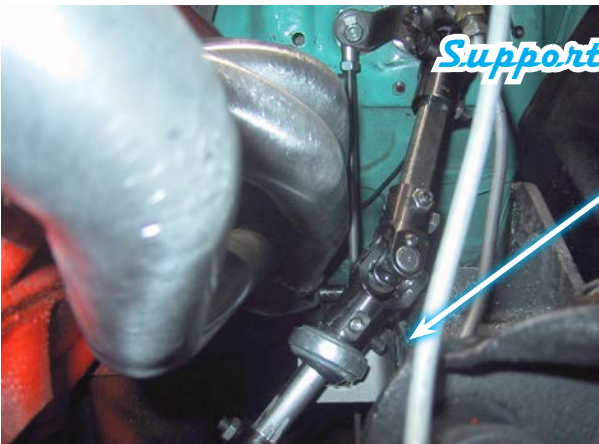

Support Bearing and Bracket



2) Install support-bearing mount onto the rear control arm bolt (Picture above). Note: The angle of this mount is set for most applications. Some adjustment may be necessary for the correct angle and u-joint alignment.

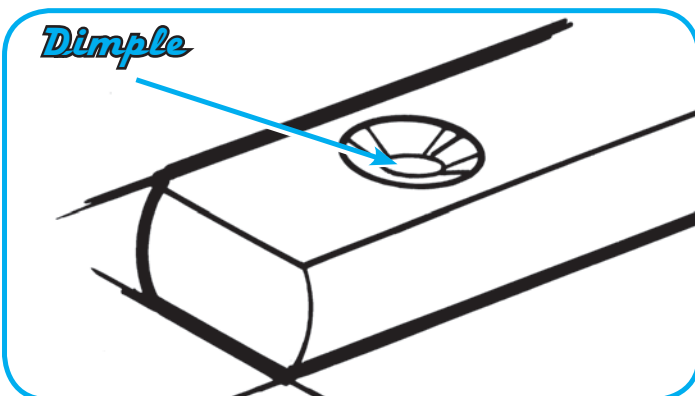

3) We recommend the use of $\frac{3}{4}$ " wood dowel rod to mock up the steering shaft to obtain the correct length of the shafts.

4) Install your shaft kit and snug each set screw so that it will leave a mark in the shafts.

5) Remove shaft and dimple each set screw mark using a $\frac{1}{4}$ " drill bit. (As shown below.)

6) Re-install the shafts using red loc-tite thread locker on the set screw threads. Tighten each set screw to 25 ft. lbs. Tighten all lock nuts securely. We recommend that you inspect set screws periodically for tightness.

**Now That the Cradle System is Installed,
Install Your New Flaming River Column**



FR20005 (55-56 Floor Shift) In kit FR306KT or FR307KTPW



FR20023 (55-56 Column Shift) In kit FR309KT or FR309KTPW



FR20005-57 (57 Floor Shift) In kit FR308KT or FR308KTPW



FR20023-57 (57 Column Shift) In kit FR310KT or FR311KTPW

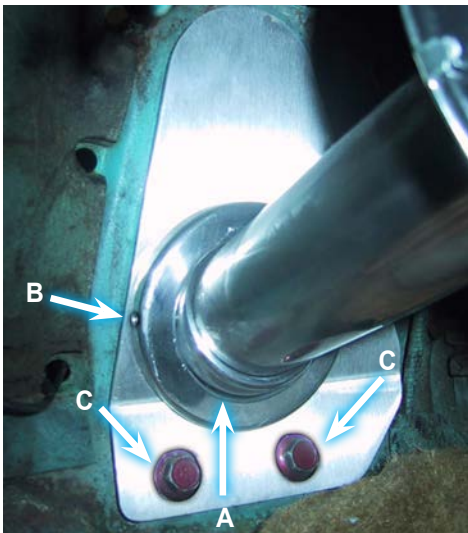

1) Remove pivot ball (A) from assembly by removing the two socket head screws (B). Next, slide the pivot ball over the column tube and then place the main body of the assembly over the pivot ball and lightly snug the two socket head screws (B). Attach the entire assembly to the floor as shown with the original mounting bolts (C).

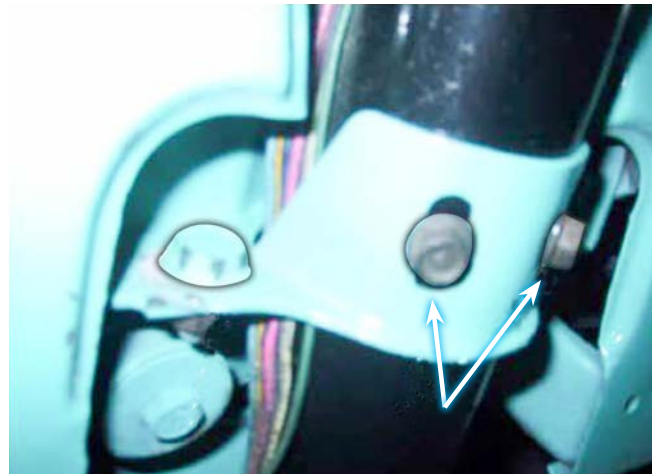

2) Place the factory dash mount onto the new column and install in the factory position. Then tighten the two socket head screws (white arrow).

Installation of Flaming River Steering Column (Continued)

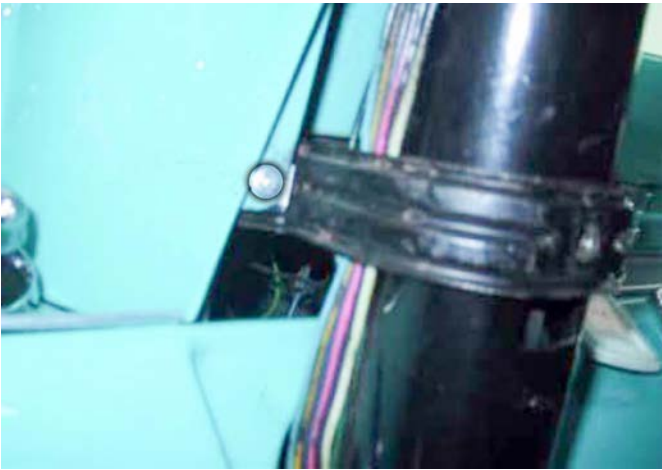

3) Replace the lower dash shroud mounting bracket using the screws that were removed earlier.

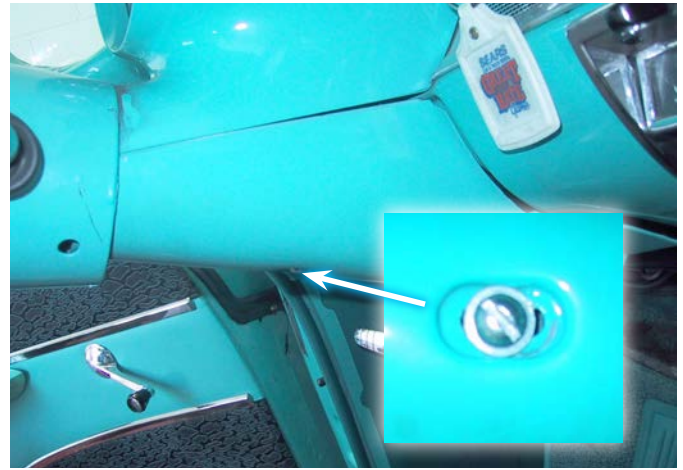

4) Replace the lower dash shroud using the screw that was removed earlier.

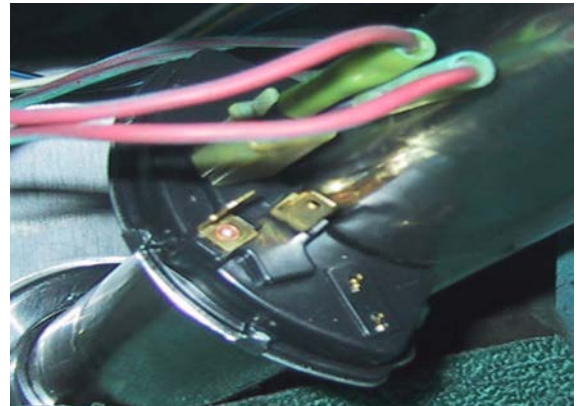

5) Column Shift Only: Plug in the neutral safety switch.

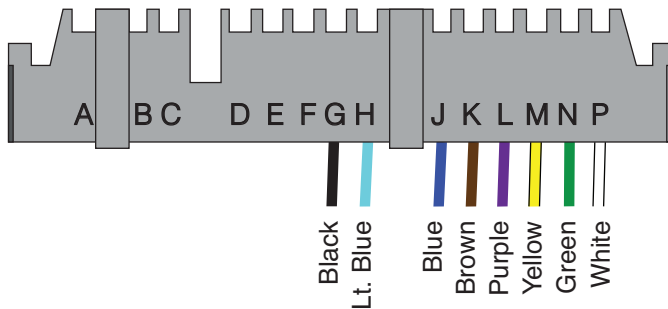

Flaming River Column Wiring

<u>Wiring Circuit</u>	<u>Pin Location</u>	<u>Column Wiring Color</u>
Brake Light Switch	P	White
Right Rear Turn Signal	N	Dark Green
Left Rear Turn Signal	M	Yellow
Turn Signal Power	L	Purple
Hazard Power	K	Brown
Right Front Turn Signal	J	Dark Blue
Left Front Turn Signal	H	Light Blue
Horn	G	Black

Color Verification to be completed before disassembly

- Brake Light Switch : _____
- RR Turn Signal : _____
- LR Turn Signal : _____
- Turn Signal Power : _____
- Hazard Power : _____
- RF Turn Signal : _____
- LF Turn Signal : _____
- Horn : _____

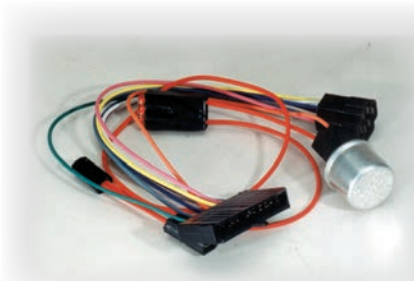

If using optional Hazard Kit, plug in the corresponding ends to the Flaming River column and to the factory harness according to the instructions above.

Tri-5 Hazard Kit.

FR20115 – 1955 • FR20116 – 1956 • FR20117 – 1957

FR1612 Small Block Chevy Power Steering Pump Bracket

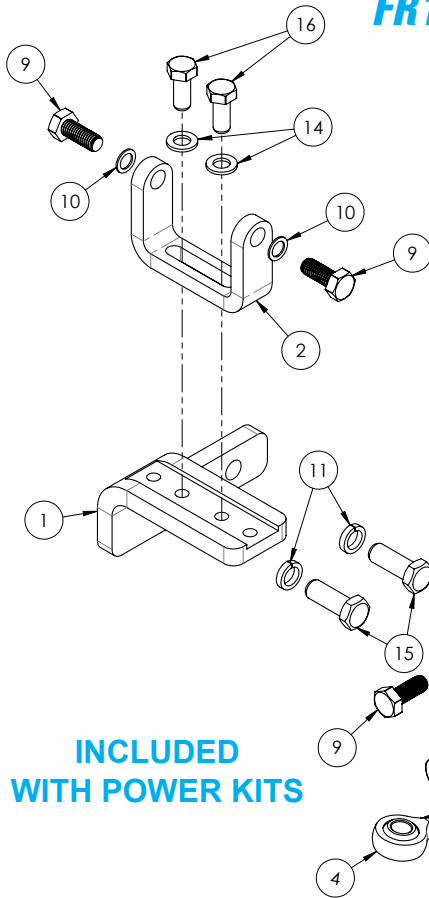

**INCLUDED
WITH POWER KITS**

ITEM NO.	QTY.	PART NUMBER	DESCRIPTION
1	1	100632	BRACKET, MOUNT PUMP-MOTOR SB
2	1	100633	BRACKET, MOUNT PUMP PS
3	1	100667	HEIM JOINT, END ROD 3/8-24 RH
4	1	100668	HEIM JOINT, END ROD 3/8-24 LH
5	1	100720	SPACER, ADJ 0.62 X 2.52 W/ 3/8-24 RH-LH
6	1	100721	SPACER, 0.392 X 0.62 X 1.00 ALUM
7	1	100722	BOLT, 3/8-16 X 3.00 HEX HD GR8
8	1	100723	WASHER, FLAT 0.39 X 0.62 X .05
9	3	100724	BOLT, M8 X 1.25 X 20 HEX HD GR10.9
10	3	100725	WASHER, FLAT 0.32 X 0.47 X .04
11	2	100726	WASHER, LOCK SPLIT 3/8 HIGH COLLAR
12	1	100728	NUT, 3/8-24 JAM LH
13	1	100729	NUT, 3/8-24 JAM RH
14	2	100730	WASHER, FLAT 0.32 X 0.57 X .06
15	2	100779	SCREW, 3/8-16 X 1.00 HEX HD GR8
16	2	102725	SCREW, 5/16-18 X .75 HEX HD GR8



800 Poertner Dr., Berea, Ohio 44017 • 1-800-648-8022

Power Steering Pump Installation/Small Block Chevy

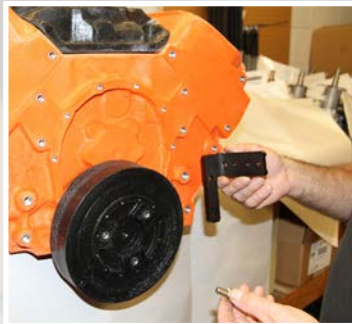

Install L-shaped bracket (1) on engine with bolts (15) and lockwashers (11) supplied



Install pump bracket (2) to L-shaped bracket (1) with bolts (16) and washers (14) supplied



Install pump to bracket (2) using bolts (9) and washers (10) supplied



Install adjuster to pump using bolt (9) and washer (10) supplied



Remove upper water pump bolt. Install spacer (6) and adjuster with bolt (7) and washer (8) supplied

FR1613 Big Block Chevy Power Steering Pump Bracket

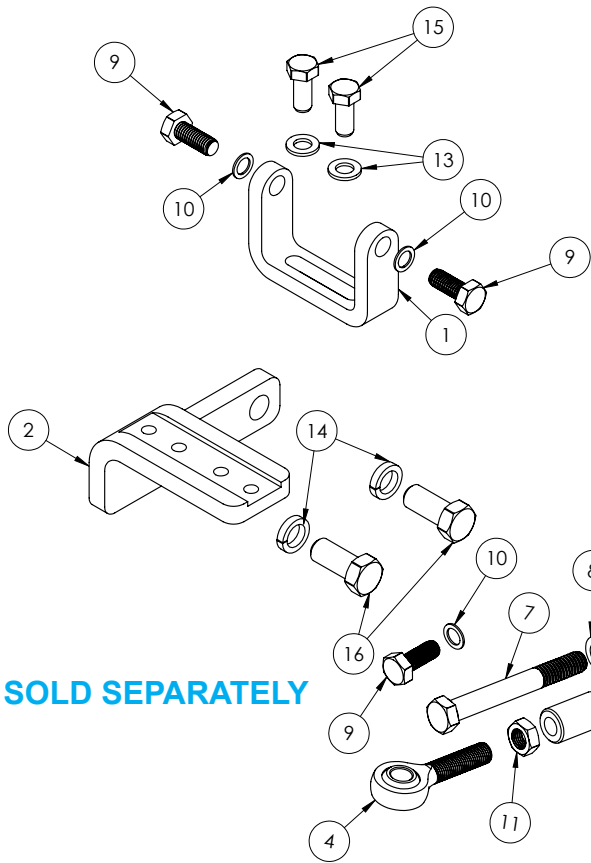

ITEM NO.	QTY.	PART NUMBER	DESCRIPTION
1	1	100633	BRACKET, MOUNT PUMP PS
2	1	100649	BRACKET, MOUNT PUMP-MOTOR SB
3	1	100667	HEIM JOINT, END ROD 3/8-24 RH
4	1	100668	HEIM JOINT, END ROD 3/8-24 LH
5	1	100720	SPACER, ADJ 0.62 X 2.52 W/ 3/8-24 RH-LH
6	1	100721	SPACER, 0.392 X 0.62 X 1.00 ALUM
7	1	100722	BOLT, 3/8-16 X 3.00 HEX HD GR8
8	1	100723	WASHER, FLAT 0.39 X 0.62 X .05
9	3	100724	BOLT, M8 X 1.25 X 20 HEX HD GR10.9
10	3	100725	WASHER, FLAT 0.32 X 0.47 X .04
11	1	100728	NUT, 3/8-24 JAM LH
12	1	100729	NUT, 3/8-24 JAM RH
13	2	100730	WASHER, FLAT 0.32 X 0.57 X .06
14	2	100732	WASHER, LOCK SPLIT 7/16 HIGH COLLAR
15	2	102725	SCREW, 5/16-18 X .75 HEX HD GR8
16	2	BOLT-7/16-14X1	BOLT, 7/16-14 X 1.00 HEX GR8

SOLD SEPARATELY



800 Poertner Dr., Berea, Ohio 44017 • 1-800-648-8022

Power Steering Pump Installation/Big Block Chevy



Install L-shaped bracket (2) on engine with bolts (16) and lockwashers (14) supplied



Install pump bracket (1) to L-shaped bracket (2) with bolts (15) and washers (13) supplied



Install pump to bracket (1) using bolts (9) and washers (10) supplied



Install adjuster to pump using bolt (9) and washer (10) supplied



Remove upper water pump bolt. Install spacer (6) and adjuster with bolt (7) and washer (8) supplied



Instruction Bulletin #1021

Correct Bleeding Procedure for Flaming River Power Rack & Pinion Systems.

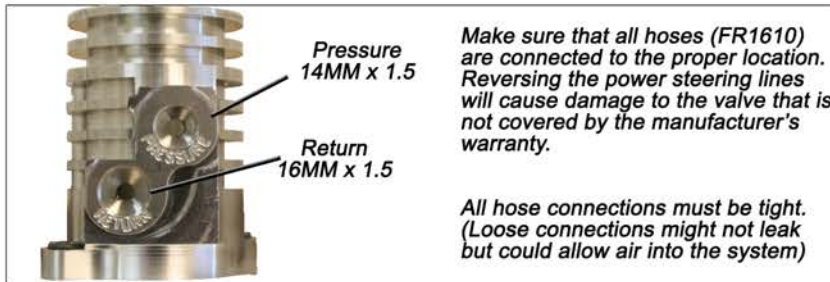

Make sure that all hoses (FR1610) are connected to the proper location. Reversing the power steering lines will cause damage to the valve that is not covered by the manufacturer's warranty.

All hose connections must be tight. (Loose connections might not leak but could allow air into the system)

Important

***** Power Steering Fluid*****
Use clean, new power steering fluid only.

- 1) Turn Ignition Off
- 2) Raise front wheels off the ground.
- 3) Turn the steering wheel full left.
- 4) Fill fluid level to "Full Cold" level or if using remote reservoir 1" over inner tube.
- 5) With assistant checking fluid level and condition, turn steering wheel lock to lock at least 20 times.
- 6) While turning wheels check fluid level constantly.
- 7) Start engine. With engine idling, maintain fluid level. Reinstall cap.
- 8) Return wheels to center. Lower front wheels to the ground.
- 9) Keep engine running for two (2) minutes.
- 10) Turn steering wheel in both directions.
- 11) If all proper conditions apply, bleeding is complete.
- 12) If any problem remains see "Special Conditions".

Verify:
Smooth power assist
Noiseless operation
Proper fluid level
No system leaks
Proper fluid condition
No bubbles, no foam,
no discoloration.

Note: On systems with long return lines or fluid coolers, turn steering wheel lock to lock at least 40 times.

Trapped air may cause fluid to overflow. Thoroughly clean spilled fluid to allow for leak check.

Note: No bubbles are allowed.

For any sign of bubbles, recheck connections then repeat step 5.

Special Conditions:



- Foam or bubbles in fluid
- Fluid must be completely free of bubbles. In step 5, be alert to periodic bubbles that could indicate a loose connection or leaky O-Ring seal in either the return hose or pressure hose.
- Discolored fluid (milky, opaque, or light tan color)

Switch ignition off. Wait two (2) minutes. Recheck hose connections. Repeat steps 7-10. If condition still exists, replace and check a possible cause:

- Return hose clamps
- Return hose o-ring
- Pressure hose o-ring
- Gear cylinder line o-rings

Fill system and repeat bleed procedure for each possible cause. Repeat steps 7-10 to verify whether noise has been eliminated.



- Pump whine or groan
- With engine running, recheck hoses for possible contact with frame body or engine. If no contact is found, follow either method below to cool down fluid and re-pressurize system.

Method 1:
Normal Cool Down

Switch engine off.
Wait for system to cool.
Install reservoir cap.

Method 2:
Partial Fluid Replacement

Switch engine off. Use a Suction device to remove fluid from the reservoir. Refill with cool, clean fluid. Install Reservoir cap.

After either method of cooling, start engine and allow engine to reach normal operating temperature. If noise persists, remove and replace power steering pump. Repeat bleed procedure following pump replacement.

WARRANTY DISCLAIMER:

Flaming River® warrants its products to be free from defects in material and workmanship for a period of one (1) year after the date of purchase. It is the customer's responsibility to determine the suitability of a given Flaming River® product for the customer's uses. Use qualified chassis specialists for the installation of all steering related components. Be aware that the installation of certain Flaming River® products may adversely impact a manufacturer's warranty with respect to certain vehicles and other manufactured goods. Flaming River will repair or replace any product found to be defective in material or workmanship. Improper installation, abuse, racing and/or modification VOID WARRANTY. Flaming River® is not responsible for any labor costs associated with any warranty.

Additional Installation Accessories (Sold Separately)



Ultra Angle Exhaust Headers FR50001C



Power Steering Hose Kit FR1610

FR1610 Hose Kit Routing

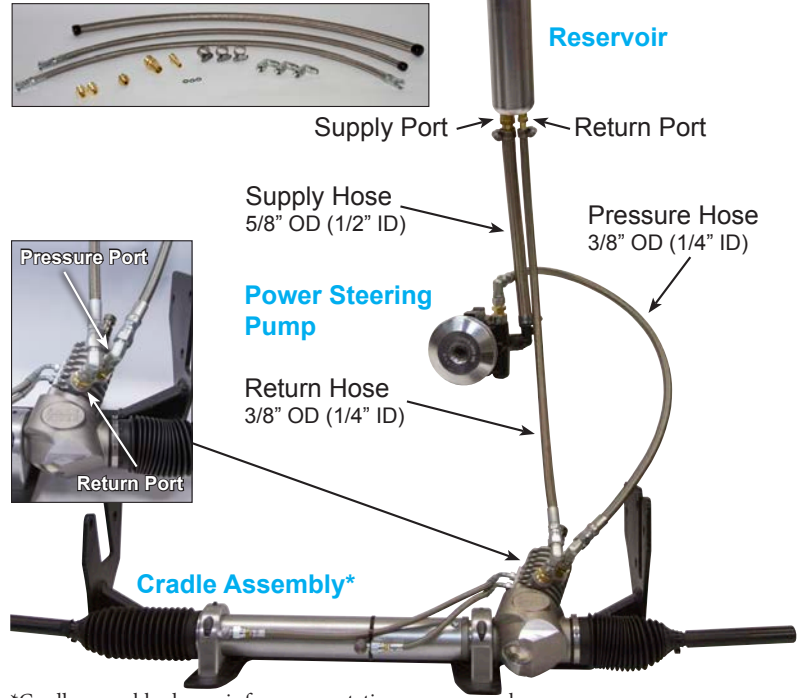

*Cradle assembly shown is for representation purposes only



If not using our hose kit, we recommend purchasing the FR1632 Pressure and Return fittings kit. If you have any questions regarding connecting alternate hose kit to Flaming River Cradle Assembly, please call 1-800-648-8022.

In order to ensure the best customer experience possible, we've created a Customer Satisfaction Survey to gather important feedback about different facets of our business. We would appreciate it if you could please take a couple of minutes to fill out this survey about your experience.

The results of the survey will be used to improve and gather feedback about customer service, technical and sales support, order processing and fulfillment, manufacturing, and new product development.

Upon completing the survey, you will be issued a discount coupon code to be used on your next online purchase at www.flamingriver.com/survey.



**Flaming River Ind.
800 Poertner Dr
Berea, OH 44017
800-648-8022**